

Table of contents

	Page
Safety notes/ Technical support	2

Introduction	3

Technical data	4

Approvals	12

Options	13

Mounting	14

Electrical installation	18

Signal output/ Diagnostics	24

Settings Sensitivity	29

Maintenance	30

Notes for use in Hazardous Locations	31

Assembly VN ..040	34

Assembly VN ..020/ VN ..030 with separate housing	39

Disposal	41

Subject to technical change and price change.

All dimensions in mm (inches).

We assume no liability for typing errors.

Different variations to those specified are possible.
 Please contact our technical consultants.

Safety notes / Technical support

Notes

- Installation, maintenance and commissioning must be carried out only by qualified technical personnel.
- The product must be used only in the manner outlined in this instruction manual.

Special attention must be paid to warnings and notes as follows:



WARNING

Relates to a caution symbol on the product and means, that a failure to observe the necessary precautions can result in death, serious injury and/ or considerable material damage.



WARNING

Relates to a caution symbol on the product: Risk of electric shock



WARNING

Relates to a caution symbol on the product and means, that a failure to observe the necessary precautions can result in death, serious injury and/ or considerable material damage.

This symbol is used, when there is no corresponding caution symbol on the product.

CAUTION

A failure to observe the necessary precautions can result in considerable material damage.

Safety symbols

In manual and on product

Description



CAUTION: refer to accompanying documents (manual) for details.



Earth (ground) Terminal



Protective Conductor Terminal

Technical support

Please contact your local supplier (see www.uwt.de for address). Otherwise you can contact:

UWT GmbH
 Westendstr. 5
 87488 Betzigau
 Germany

Tel. 0049 (0)831 57123-0
 Fax. 0049 (0)831 76879
info@uwt.de
www.uwt.de

Introduction

Applications

The device is used for level monitoring in all types of containers and silos.

It can be used with all powdery and granulated bulk materials that do not show a strong tendency to form crusts or deposits. Detection of solids in water is also possible.

The units can be delivered with a wide range of Ex-approvals for use in Gas and Dust Hazardous Areas.

A selection of fields of application:

- **Building materials industry**
lime, styrofoam, moulding sand, etc.
- **Food industry**
milk powder, flour, salt, etc.
- **Plastics industry**
plastics granules etc.
- **Timber industry**
- **Chemical industry**
- **Mechanical engineering**

The VIBRANIVO oscillating probe is normally screwed into the lateral container wall so that it is level with the filling height to be registered and monitored.

The device can also be mounted from the top of the container. In this case an extension piece is used to mount the probe level with the height to be registered.

The length of the probe can be up to 4 m (157") with an extension tube (VN ..030) or up to 20 m (787") with an extension rope (VN 2050/ 6050).

The use of a sliding sleeve is recommended so that the switch point can be changed easily during operation of the device.

Function

The piezo-electrically stimulated oscillating fork vibrates at its mechanical resonance frequency. If the probe is covered by the bulk material, the damping thus generated is registered electronically and a corresponding signal output is actuated.

The oscillation of the fork ensures a certain self-cleaning.

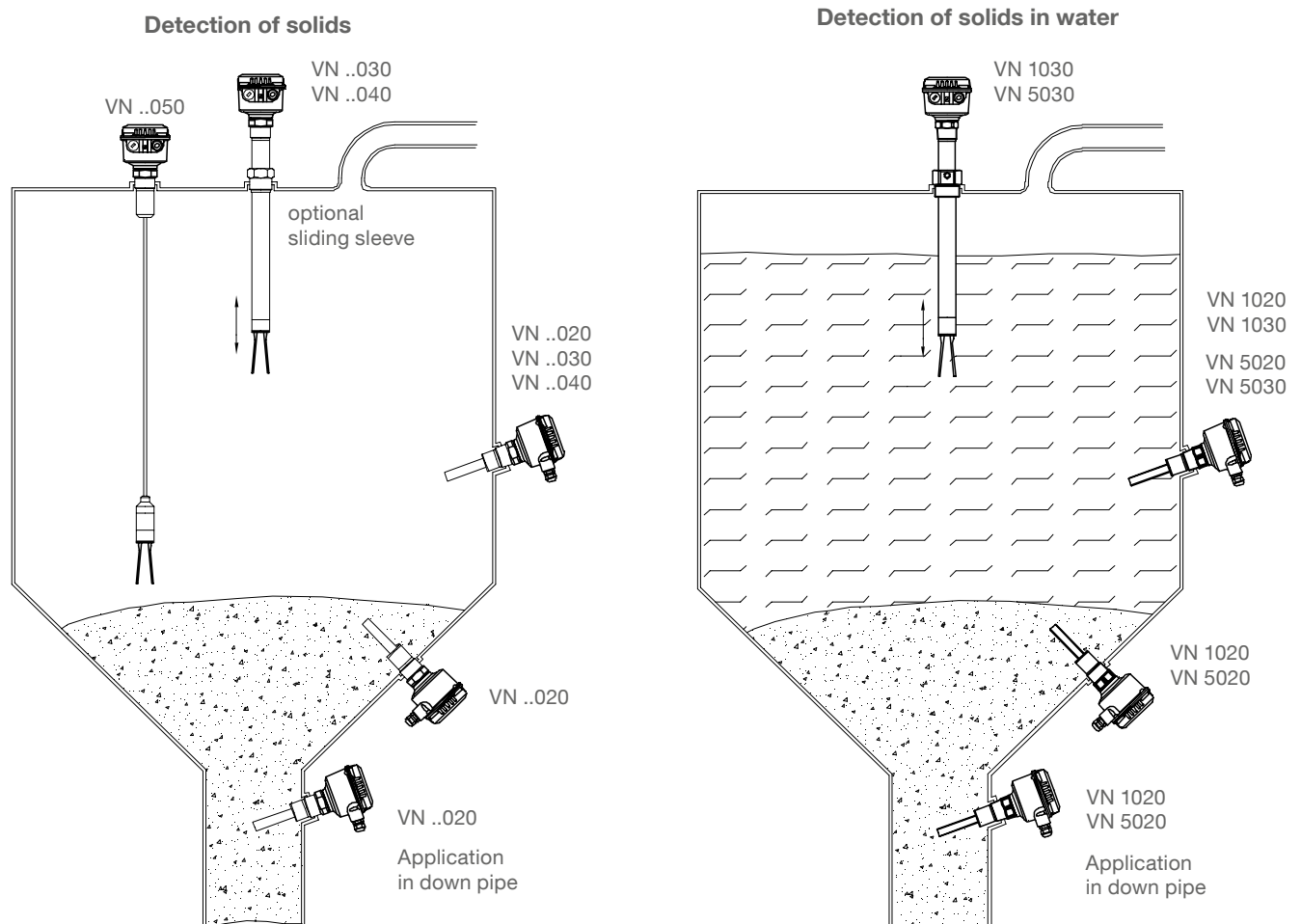

Technical data

Housing versions

Series VN 1000/ 2000

Standard

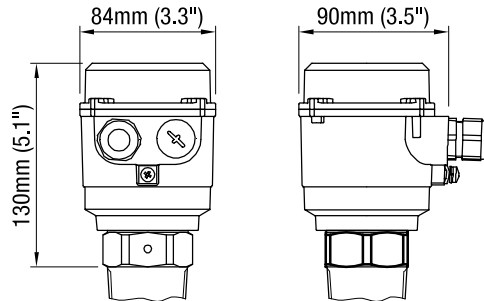

Series VN 5000/ 6000

Standard

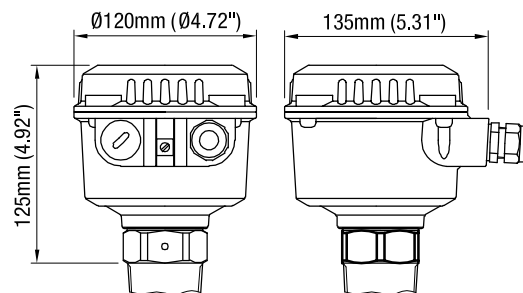

de

Explosionproof with
 increased safety
 terminal box

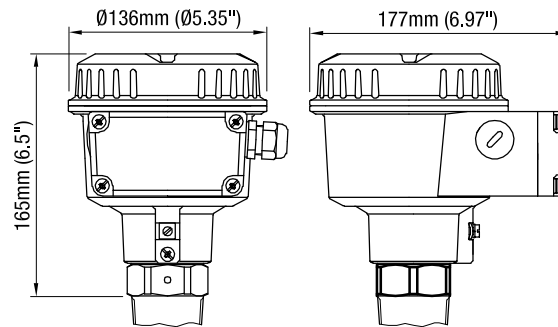

d

Flameproof/
 explosionproof

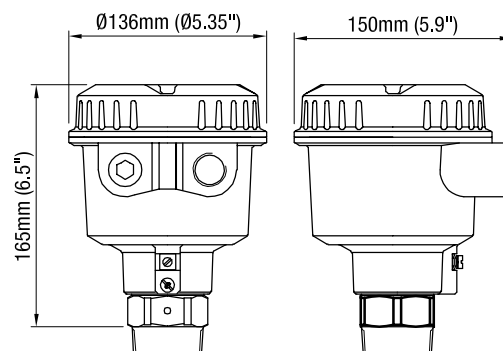

Technical Data

Extensions

VN ..020

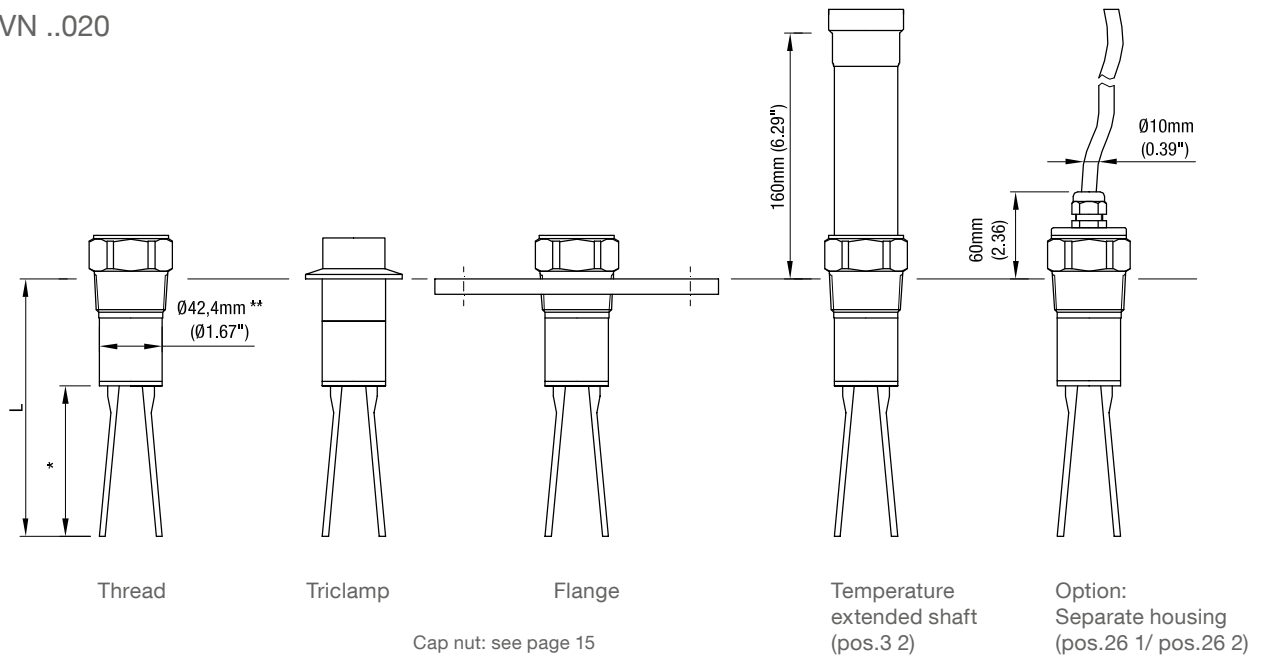

	L	
	without option	with option: enhanced sensitivity (pos.26 x) Vibrasil 70 (pos.26 a) Vibrasil 90 (pos.26 b)
VN 1020 VN 5020	165 mm (6.5")	
VN 2020 VN 6020	235 mm (9.25")	260 mm (9.84")

* see page 6 bottom right
 ** Welding seam max. $\varnothing 43.8$ mm ($\varnothing 1.72$ ")

VN ..030

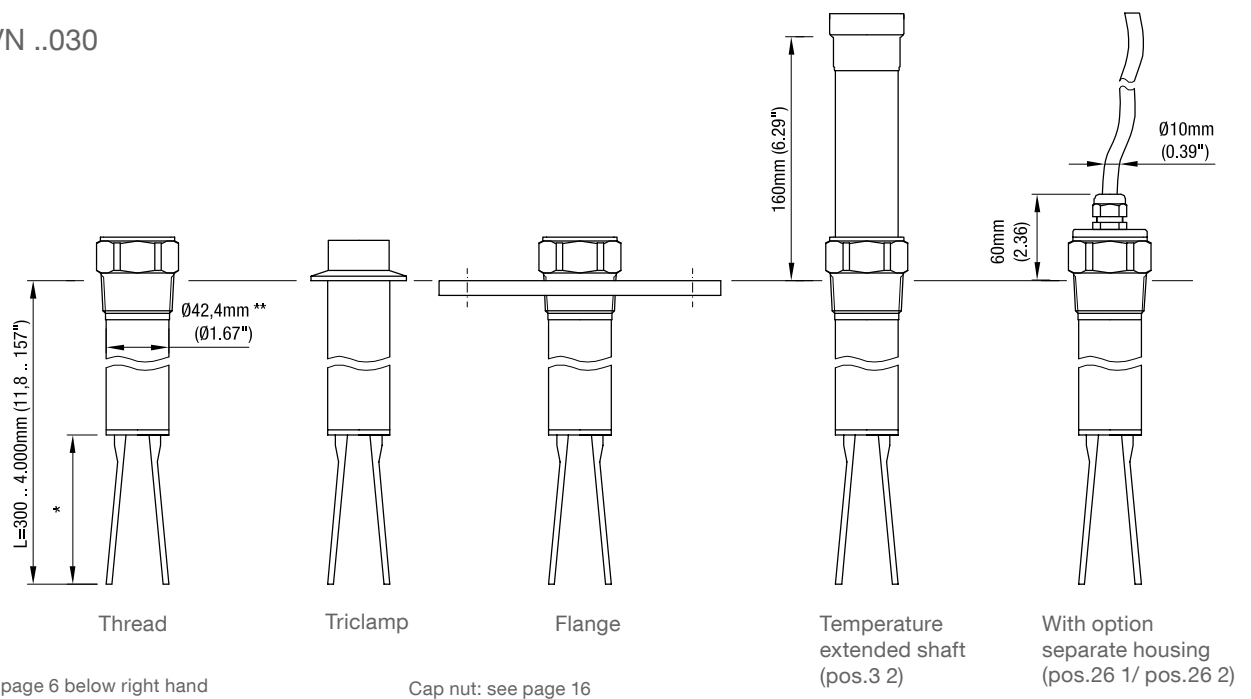

* see page 6 below right hand
 ** Welding seam max. $\varnothing 43.8$ mm ($\varnothing 1.72$ ")

Technical data

VN ..040

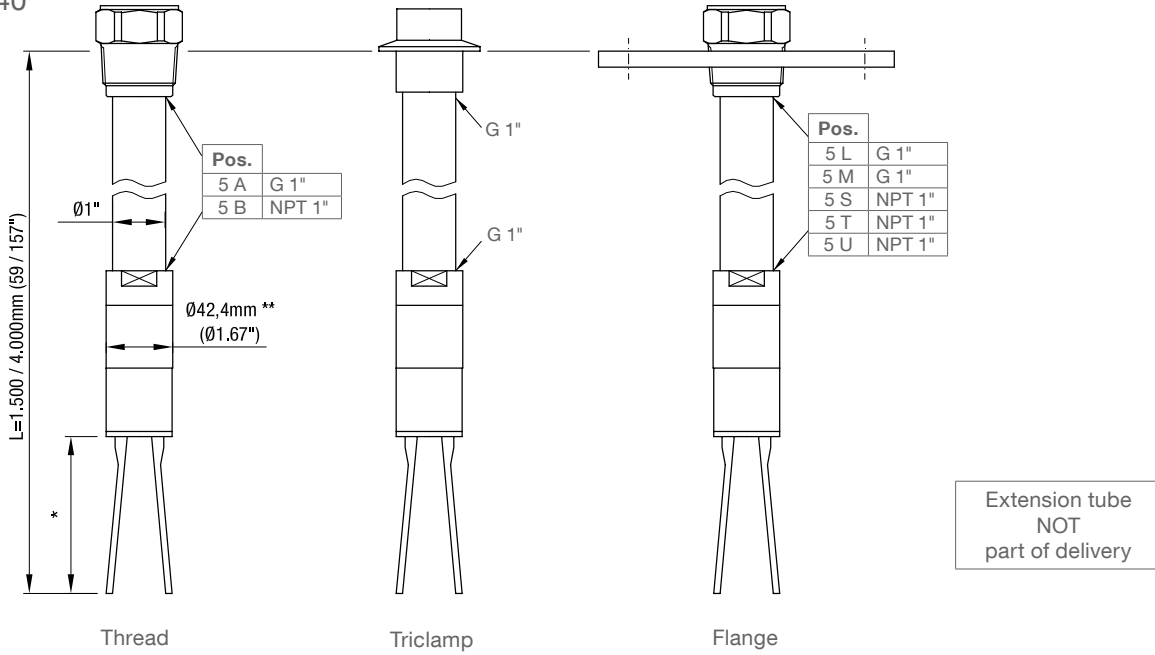

* see bottom right

** Welding seam max. $\varnothing 43.8$ mm ($\varnothing 1.72$ ")

VN ..050

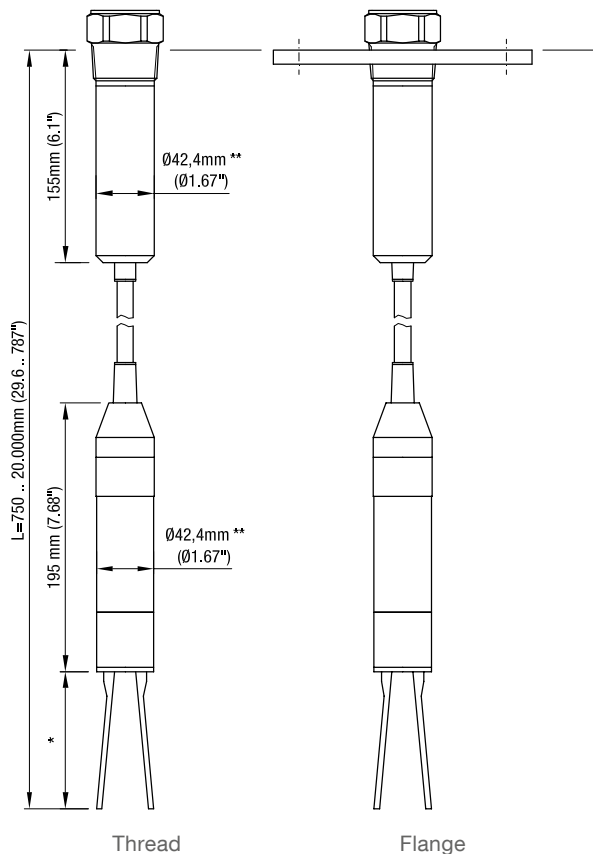

* Length of oscillating rods

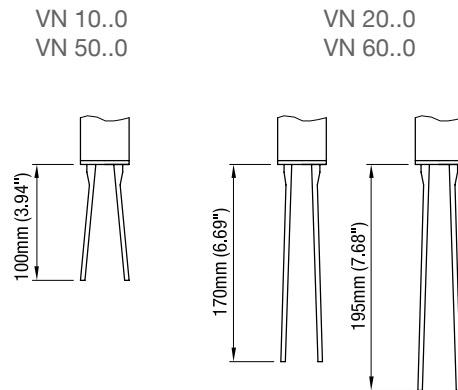

with option
 Enhanced sensitivity (pos.26 x)
 Vibrasil® 70 (pos.26 a)
 Vibrasil® 90 (pos.26 b)

* see right

** Welding seam max. $\varnothing 43.8$ mm ($\varnothing 1.72$ ")

Technical data

Electrical data

Connection terminals	max. 4 mm ² (AWG 12)
Cable entry	M20 x 1.5 screwed cable gland NPT ½" conduit connection NPT ¾" conduit connection (only VN 5000/ 6000) Clamping range (diameter) of the factory provided cable glands: M20 x 1.5: 6 .. 12 mm (0.24 .. 0.47")
Signal delay	Sensor free -> covered ca. 1 sec Sensor covered -> free ca. 1 .. 2 sec On the electronic module "Universal voltage Relay DPDT" is an electronic delay, adjustable up to 30 sec.
Safety operation (FSL,FSH)	Switchable for minimum or maximum safety
Sensitivity	Adjustable in 2 levels (A/ B)
Vibration frequency	VN 1000/ 5000: ca. 350 Hz VN 2000/ 6000: ca. 125 Hz ca. 90 Hz (enhanced sensitivity)
Installation category	II
Pollution degree	2 (inside housing)

Electronic modules	Universal voltage Relay SPDT (VN 1000/ 2000/ 5000/ 6000)	Universal voltage Relay DPDT (VN 1000/ 2000/ 5000/ 6000)	3-wire PNP (VN 1000/ 2000/ 5000/ 6000)
Power supply	19 .. 230 V AC 50 - 60 Hz 19 .. 55 V DC +10%	19 .. 230 V AC 50 - 60 Hz 19 .. 55 V (36 V*) DC +10% * Version with intrinsic safe connection between Electronic module and Vibrating fork (see pos.4 in the selection list)	18 .. 50 V DC +10%
Max. ripple of power supply	7 V _{ss} at DC	7 V _{ss} at DC	7 V _{ss}
Installed load	max. 8 VA/ 1.5 W	max. 18 VA/ 2 W	max. 1.5 W
Signal output	Floating relay SPDT VN 1000/ 2000: AC max. 253 V, 4 A, 500 VA at cos Phi = 1 DC max. 253 V, 4A, 60 W VN 5000/ 6000: AC max. 250 V, 8 A non inductive DC max. 30 V, 5 A non inductive	Floating relay DPDT VN 1000/ 2000: AC max. 253V, 4 A, 500 VA at cos Phi = 1 DC max. 253 V, 4 A, 60 W VN 5000/ 6000: AC max. 250 V, 8 A non inductive DC max. 30 V, 5 A non inductive	Open Collector: permanent load max. 0.4 A short-circuit and overload protected turn-on voltage: max. 50 V (reverse protection)
Intrinsic safe ratings	-	-	-
Indicating light	Status of signal output by built-in LED	Status of signal output by built-in LED	Status of signal output by built-in LED
Isolation	Power supply to signal output: 2225 Vrms	Power supply to signal output: 2225 Vrms Signal output to signal output (DPDT): 2225 Vrms	-
Protection class	I	I	III

Technical data

Electronic modules	2-wire without contact (VN 1000/ 2000/ 5000/ 6000)	NAMUR IEC 60947-5-6 (VN 2000/ 6000)	8/16 mA or 4-20 mA (VN 1000/ 2000/ 5000/ 6000)	8/16 mA (VN 1000/2000/ 5000/ 6000)
Power supply	19 .. 230 V 50/ 60 Hz/ DC +10%	ca. 7 .. 9 V DC (spec. IEC 60947-5-6)	Non intrinsic safe version: 12.5 .. 36 V DC +0% Intrinsic safe version: 12.5 .. 30V DC +0%	12.5 .. 36 V DC +0%
Max. ripple of power supply	7 V _{ss} at DC	-	-	-
Installed load	max. 1.5 VA/ 1 W	max. 30 mA (for non intrinsic safe application)	max. 0.8 W	max. 0.8 W
Signal output	<p>Load current: min. 10 mA max. 500 mA permanent max. 2 A <200 ms max. 5 A <50 ms Voltage drop on the electronic module: max. 7 V with closed electric circuit.</p> <p>Cutoff current with open electric circuit: max. 5 mA.</p> <p>To enable a safe opening of relay contacts, the cutoff current will be set for some milliseconds to 0, when opening the electric circuit.</p> <p>Short-circuit- and overload-protected.</p>	<1 mA or >2.2 mA (spec. IEC 60947-5-6)	<p>Setting 8/16 mA: 8 mA or 16 mA ±0.5 mA.</p> <p>Setting 4-20 mA: Output current depends on the vibration amplitude of the fork between 6 mA for damped vibration and 20 mA for full vibration. Resolution is 0.1 mA.</p>	8 mA or 16 mA ±1 mA
Intrinsic safe ratings	-	<p>U_i 20 V I_i 67 mA P_i 0.17 W C_i negligible small L_i negligible small</p>	<p>Intrinsic safe version: U_i 30 V I_i 130 mA P_i 0.8 W C_i negligible small L_i negligible small</p>	-
Indicating light	Status of signal output by built-in LED	Status of signal output and diagnostics of vibration by built-in LED	Status of signal output and diagnostics of vibration by built-in LED	Status of signal output by built-in LED
Protection class	I	III	III	III

Technical data

Mechanical data

Housing	Aluminium housing, powder coated RAL 5010 gentian blue Seal between housing and lid: NBR Seal between housing and process connection: NBR Nameplate: polyester film		
Cable for separate housing	Silicone elastomer, ø10 mm (ø0.39"), surface resistance <math><10^9</math> Ohm, UV-resistant, min. bending radius 50 mm (1.97")		
Degree of protection	VN 1000/ 2000:	IP66*	
	VN 5000/ 6000:	NEMA Type 4X, IP66*	
	* IEC/ EN 60529		
Process connection/ extension L	VN ..020/ ..030/ ..050: Stainless steel 1.4301 (304)* or 1.4404 (316L) VN ..40: Stainless steel 1.4305 (303)* or 1.4404 (316L) *Flanges 1.4541 (321) Extension cable VN ..050: PUR with carbon black (no food grade) Thread: R 1½" tapered EN 10226 or NPT 1½" tapered ANSI B 1.20.1 Triclamp: Stainless steel 1.4301 (304) or 1.4404 (316L) 2" (DN50) ISO 2852 Flanges according to selection		
Oscillator	Material: stainless steel 1.4404/ 1.4581 (316L) (food grade) Surface treatment of vibrating rods: polished, Ra ≤0.75 µm; teflon (on request)		
Sound level	max. 50 dBA		

Overall weight (ca.)

VN 1000/ 2000	Standard housing	Extension
VN 1020/ 2020:	1.6 kg (3.5 lbs)	-
VN 1030/ 2030:	1.6 kg (3.5 lbs)	+2.5 kg/m (+5.5 lbs per 39.3")
VN 1040/ 2040:	2.0 kg (4.4 lbs)	delivery without extension tube
VN 1050/ 2050:	4.0 kg (8.8 lbs)	+0.5 kg/m (+1.1 lbs per 39.3")

VN 5000/ 6000	Standard housing	de-housing	d-housing	Extension
VN 5020/ 6020:	2.1 kg (4.6 lbs)	3.2 kg (7 lbs)	2.8 kg (6.2 lbs)	-
VN 5030/ 6030:	2.1 kg (4.6 lbs)	3.2 kg (7 lbs)	2.8 kg (6.2 lbs)	+2.5 kg/m (+5.5 lbs per 39.3")
VN 5040/ 6040:	2.5 kg (5.5 lbs)	3.6 kg (7.9 lbs)	3.2 kg (7 lbs)	delivery without extension tube
VN 5050/ 6050:	4.5 kg (9.9 lbs)	5.6 kg (12.3 lbs)	5.2 kg (11.4 lbs)	+0.5 kg/m (+1.1 lbs per 39.3")

Technical data

Operating conditions

Ambient temp. (housing)	-40°C .. +60°C (-40 .. +140°F) -25°C .. +60°C (-13 .. +140°F)	VN ..020/ VN ..030 and VN ..040 VN ..050
Process temperature	-40°C .. +150°C (-40 .. +302°F) -40°C .. +110°C (-40 .. +230°F) -25°C .. +80°C (-13 .. +176°F)	VN ..020/ VN ..030 and VN ..040 Mounting for process temperature up to 150°C (302°F): see drawing VN ..020/ VN ..030 with Ex approval and separate housing (price list option 26.1, 26.2) VN ..050

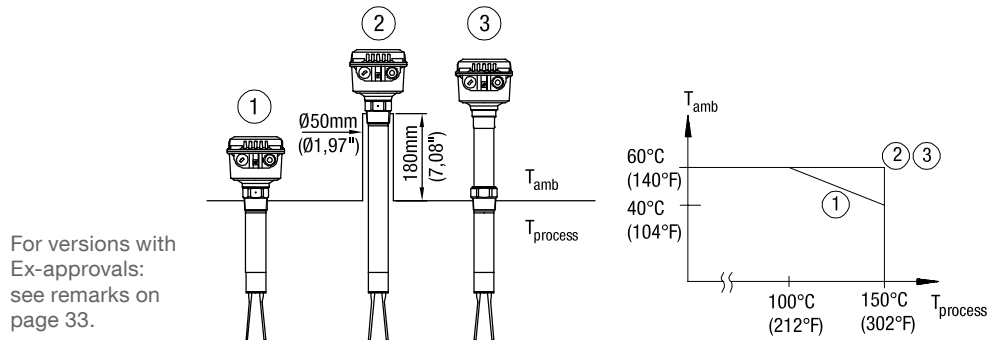

Ventilation	Ventilation is not required		
Min. powder density	VN 1000/ 5000:	Setting B ca. 50 g/l (3 lb/ft ³)	Setting A ca. 150 g/l (9 lb/ft ³)
	VN 2000/ 6000:	ca. 20 g/l (1.2 lb/ft ³) ca. 5 g/l (0.3 lb/ft ³)	ca. 75 g/l (4.5 lb/ft ³) ca. 20 g/l (1.2 lb/ft ³)
			Standard version Enhanced sensitivity
Features of bulk material	No strong caking tendencies Max. grain size 10 mm (0.39")		
Max. mechanical load	600 N laterally (on oscillator rods) Recommended protection in case of high material load: mounting of a protective canopy above the probe.		
Max. mechanical torque	300 Nm 100 Nm	VN ..030 VN ..040	
Max. tractive force	2 kN	VN ..050	
Max. process pressure	16 bar (232 psi) 16 bar (232 psi)	VN ..020, VN ..030 VN ..040 (depending on the quality of the local mounted sealing of the extension tube)	
	6 bar (87 psi)	VN ..050	
	The max. process pressure may be reduced with use of flanges. Observe flange standards for pressure rating and pressure derating with higher temperature.		
	For versions with Ex-approvals: see remarks on page 31.		

Vibration	1.5 (m/s ²) ² /Hz according to EN 60068-2-64
Relative Humidity	0 - 100%, suitable for outdoor use
Altitude	max. 2,000 m (6,562 ft)
Expected product lifetime	Following parameters have a negative influence on the expected product lifetime: High ambient- and process temperature, corrosive environment, high vibration, high flow rate of abrasive bulk material passing the sensor element.

Technical data

Transport and Storage

Transport

Observe the instructions as stated on the transport packaging, otherwise the products may get damaged.

Transport temperature: -40 .. +80°C (-40 .. +176°F)

Transport humidity: 20 .. 85%

Transport incoming inspections must be carried out to check for possible transport damage

Storage

Products must be stored at a dry and clean place. They must be protected from influence of corrosive environment, vibration and exposure to direct sunlight.

Storage temperature: -40 .. +80°C (-40 .. +176°F)

Storage humidity: 20 .. 85%

Approvals

	VN 1000	VN 2000	VN 5000	VN 6000				
Ordinary Locations*	•	•	•	•	CE FM/ CSA TR-CU	EN 61010-1		
Hazardous Locations *	•	•	•	•	ATEX	Dust explosion	ATEX II 1D Ex t IIIC T! Da IP6X and 1/2 D Ex t IIIC T! Da/Db IP6X	
	•	•	•	•		Gas explosion		Intrinsic safe
			•	•			Flameproof	ATEX II 2G Ex d [ia] IIC T! Gb
			•	•			Flameproof/ increased safety	
	•	•	•	•	IEC-Ex	Dust explosion	IEC-Ex t IIIC T! Da IP6X and t IIIC T! Da/Db IP6X	
	•	•	•	•		Gas explosion		Intrinsic safe
			•	•			Flameproof	IEC-Ex d [ia] IIC T! Gb
			•	•			Flameproof/ increased safety	
			•	•	FM	Dust explosion	Cl. II, III Div. 1 Gr. E,F,G	
			•	•		Gas explosion		Intrinsic safe
			•	•			Flameproof	Cl. I Zone 0 and 0/1 AEx ia IIC
			•	•			Flameproof/ increased safety	XP-IS Cl. I Div. 1 Gr. B-D
			•	•			Flameproof/ increased safety	Cl. I Zone 1 AEx d [ia] IIC
			•	•			Flameproof/ increased safety	Cl. I Zone 1 AEx de [ia] IIC
			•	•	CSA	Dust explosion	Cl. II, III Div. 1 Gr. E,F,G	
			•	•		Gas explosion		Intrinsic safe
			•	•			Flameproof	IS Cl. I Div. 1 Gr. A-D
			•	•			Flameproof/ increased safety	Cl. I Zone 0 and Zone 0/1 Ex ia IIC
		•	•			Flameproof/ increased safety	XP-IS Cl. I Div. 1 Gr. B-D	
		•	•			Flameproof/ increased safety	Cl. I Zone 1 Ex d [ia] IIC	
		•	•			Flameproof/ increased safety	Cl. I Zone 1 Ex de [ia] IIC	
	•	•			TR-CU	Dust explosion	Ex ta IIIC T! Da X and Ex ta/tb IIIC T! Da/Db X	
	•	•				Gas explosion		Intrinsic safe
			•	•		Flameproof	Ex d [ia] IIC T! Gb X	
			•	•		Flameproof/ increased safety	Ex de [ia] IIC T! Gb X	
	•	•	•	•	INMETRO	Dust explosion	Ex ta IIIC T! Da IP6x and Ex ta/tb IIIC T! Da/Db IP6X	
			•	•		Gas explosion		Intrinsic safe
			•	•		Flameproof	Ex d IIC T! Gb	
			•	•		Flameproof/ increased safety	Ex d [ia Ga] IIC T! Gb	
			•	•		Flameproof/ increased safety	Ex de IIC T! Gb	
			•	•		Flameproof/ increased safety	Ex d e [ia Ga] IIC T! Gb	
EMC	•	•	•	•	EN 61326 -A1			
Hygiene *	•	•	•	•	EHEDG			
RoHS conform	•	•	•	•	According to directive 2011/65/EU			
Food grade material	•	•	•	•	According to directive 1935/2004/EC			

Pressure Equipment Directive (2014/68/EU)

The units are not subject to this directive, because they are classified as „pressure-keeping equipment“ and do not have a pressurized housing (see Art.1, clause 2.1.4).

- The units are designed and manufactured in accordance to the Pressure Equipment Directive.
- The units are NOT intended for use as a “equipment part with safety function (Art.1, clause 2.1.3).
- If the units should be used as „equipment part with safety function, please contact the manufacturer.

* depending on selected version in the selection list.

Options

Weather protection-cover

When the measuring device is used outdoor, the use of the weather protection-cover is recommended. It protects the device from all atmospheric influences such as:

- rain water
- condensation of water
- excessively high temperatures due to insolation
- excessively low temperatures in winter

Material: PE, weather and temperature stable



Not available for housing version d and de.
 For use in Hazardous Locations: only permitted for zone 2 and 22 or Division 2.

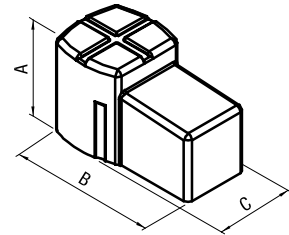

Sliding sleeve

VN ..030 G2" ISO 228 or 2" NPT ANSI B 1.20.1
 Material: 1.4301 (304) or 1.4404 (316L)
 Sealing material to the extension tube: viton

VN ..040 Because the outer diameters of the locally mounted 1" tube may differ, sliding sleeve on request.
 Not for Hazardous Locations.

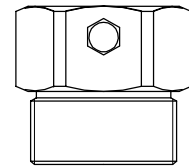

Mounting set

Screws and washers for fixing the unit on a flange.

Glass window in lid

To see the indicating light on the electronic module from outside.

Not available for housing version d and de.

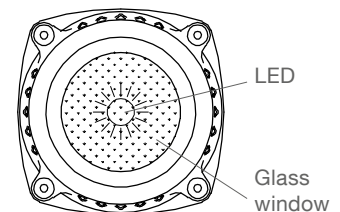

Bulb

Bright indicating light seen from outside.

Not available for use in Hazardous Locations.

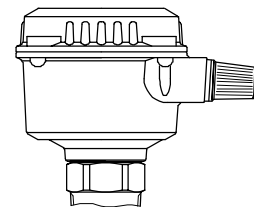

Plug 4-pole (incl. PE)

Used instead of cable gland.

Not available for use in Hazardous Locations and FM/ CSA general Purpose.

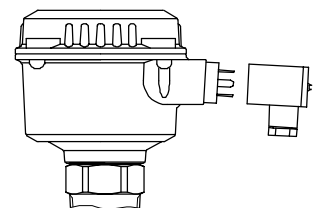

EHEDG approval

EHEDG conform design (material and construction in contact with the process).

Approved with flush welding socket
 Material: aluminium or 1.4301 (304) or 1.4404 (316L)
 (details see: mounting instructions EHEDG version, page 16).

Mounting

! General Safety Instructions

Detection of solids in water **CAUTION:**
 Detection of solids in water only permitted with types VN 1020/ 1030/ 5020/ 5030.
 Other types on request.

Process pressure Improper installation may result in loss of process pressure.

Chemical resistance against the medium Materials of construction are chosen based on their chemical compatibility (or inertness) for general purposes. For exposure to specific environments, check with chemical compatibility charts before installing.

VN ..050:
 Consider the chemical compatibility of the extension cable (material PUR) and the rubber seals on both ends of the extension cable (material neoprene).

Mechanical load The torque at the fastening spot must not exceed
 300 Nm (VN ..030) or
 100 Nm (VN ..040)

Maximum length „L“ in relation
 to the deviation (in degrees) from vertical installation:

Max. deviation	Max. length „L“
5°	4,000 mm (157.5“)
45°	1,200 mm (47.24“)
>45°	600 mm (23.62“)

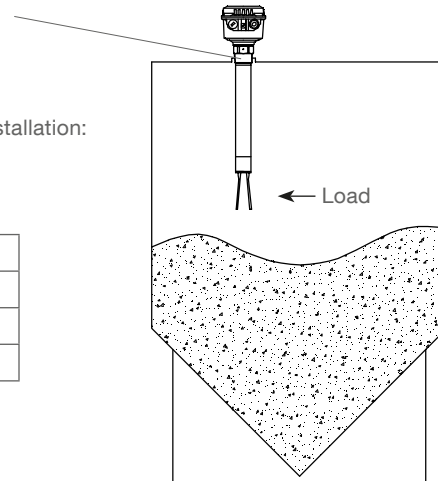

Mounting location Comply with distance from incoming material and from the silo wall.
 The installation has to be done in a way, that the sensor elements cannot hit the wall of the silo. The flow of the medium and fixtures in the container must be considered. This is especially important for extension lengths of more than 3 m (118.1“).

2“ sliding sleeve Tighten both locking screws M8 with 20 Nm
 to obtain resistance against pressure.

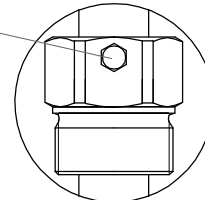

Flange mounting A plastic sealing must be used to tighten the flange.

Fastening of the 1½” process connection Mounting torque for the 1½” thread may not exceed 80 Nm.
 Use a 50 mm (1.97”) open-end wrench (do not turn the housing).

EHEDG-approval/ food grade material The materials are available for the use under normal and predictable applications (according to directive 1935/2004 Art.3). Other conditions can influence the safety.

Mounting

! Additional Safety Instructions for Hazardous Locations

Installation regulations	For the use of devices in Hazardous Locations the respectively valid installation regulations must be observed.
Sparks	The installation has to be carried out in a way, that mechanical friction or impact does not cause sparks between the aluminium enclosure and steel.
Mounting in application with Partition wall, that separates Zone 0 (Cat. 1G) from Zone 1 (Cat 2G).	<p>VN ..030 with sliding sleeve: The use of the sliding sleeve is not allowed.</p> <p>VN ..040 and VN ..050: The unit has no safe separation between Zone 0 and Zone 1. It must be considered, that gas can pass from Zone 0 through the unit to Zone 1.</p>

Mounting instructions

Oscillating rods Do not bend, shorten or extend the oscillating rods since this will destroy the device.

Rotatable housing and orientation marking of oscillating rods

The housing can be rotated against the threaded connection after mounting.
 For the d- and de- housing:
 Fixing screw must be unfastened to enable rotation. Fix the screw again, when the housing has the right position.

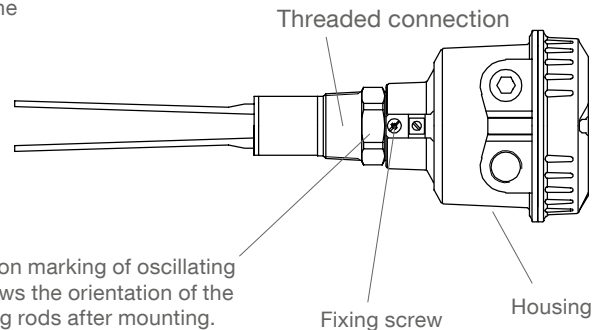

Direction of the cable glands When the unit is mounted from the side, ensure, that the cable glands are closed and face downwards to avoid water penetrating the housing.

Sealing Seal the 1½" thread with Teflon tape in case of process pressure

Precaution for later dismantling/ Service Grease the screws of the lid if corrosive atmosphere is present (e.g. close to sea)

Switching point
 Heavy bulk material -> the signal output switches, when the oscillating rods are covered a few mm.
 Light bulk material -> the signal output switches, when the oscillating rods are covered a few cm.

Mounting

EHEDG-approval

The sealing ring ensures a pressure tight sealing of the process connection.

Metal-metal sealing:

- The support muß be plane and without any gap.
- Fixing torque 100 Nm

The quality of the welding with the container wall must be according to the respective regulations (e.g. gaps, transitions, surface finish).

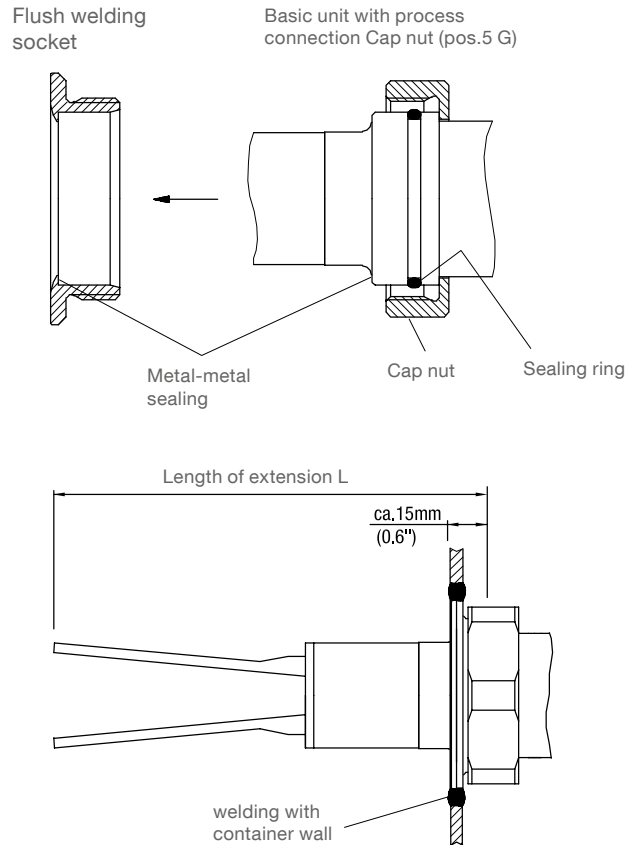

Dimension of flush welding socket (for optional on site manufacturing):

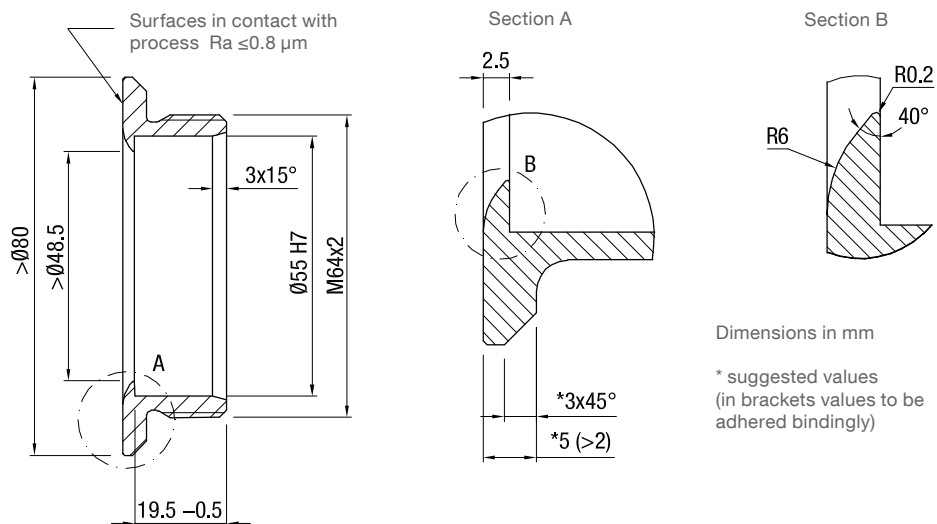

Mounting

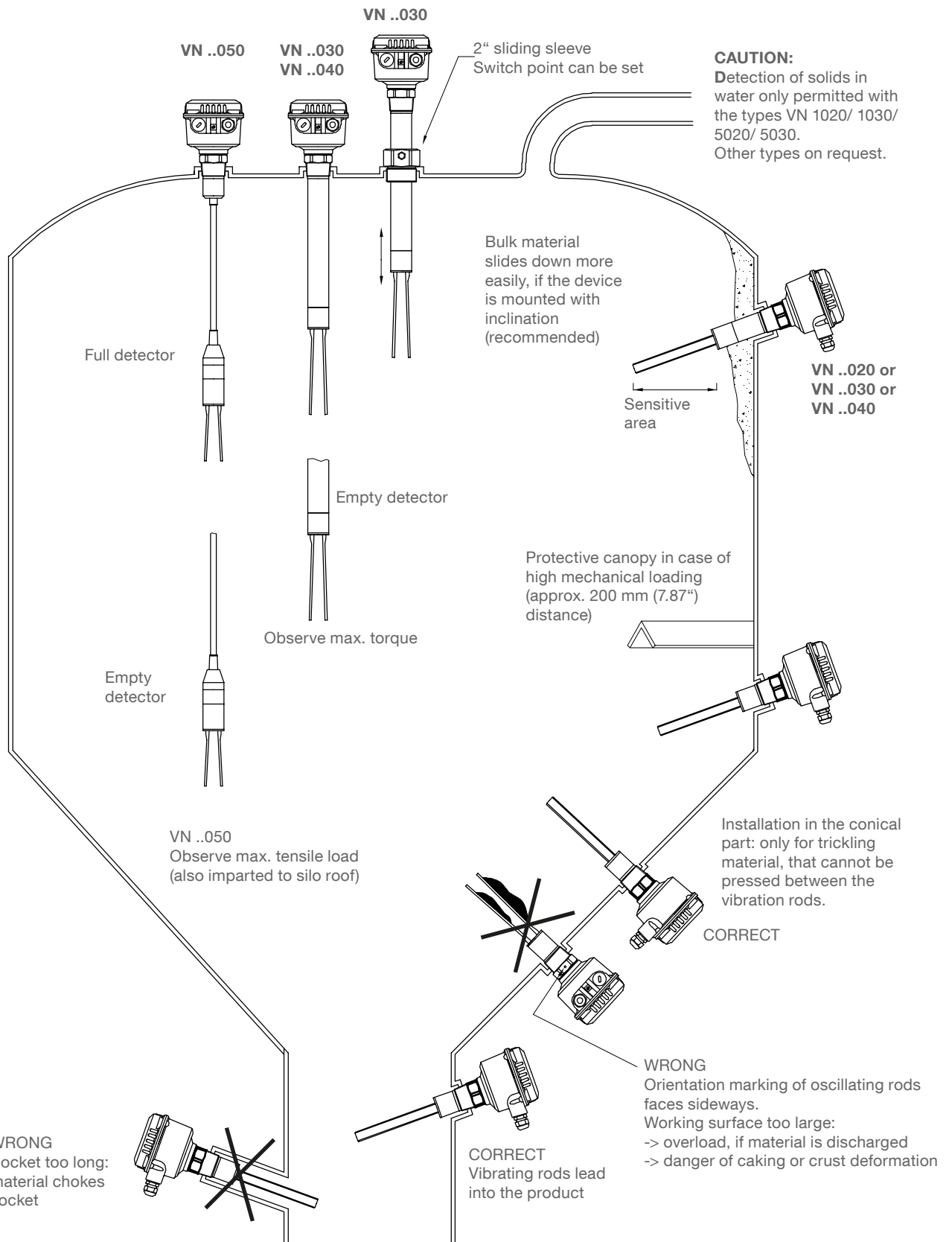

Electrical installation

! General Safety Instructions

Handling	In case of inexpert handling or handling malpractice, the electric safety of the device cannot be guaranteed.
Installation regulations	The local regulations or VDE 0100 (Regulations of German Electrotechnical Engineers) must be observed. With use of 24 V supply voltage, an approved power supply with reinforced insulation to mains is required.
Fuse	Use a fuse as stated in the connection diagrams (page 22 and 23).
RCCB protection	In the case of a defect, the distribution voltage must automatically be cut off by a RCCB protection switch to protect the user of the device from indirect contact with dangerous electric tensions.
Power supply switch	A voltage-disconnecting switch must be provided near the device.
Wiring diagram	The electrical connections are made in accordance with the wiring diagram.
Supply voltage	Compare the supply voltage applied with the specifications given on the electronic module and name plate before switching the device on.
Cable gland	Make sure that the screwed cable gland safely seals the cable and that it is tight (danger of water intrusion). Cable glands that are not used have to be locked with a closing element.
Conduit system	In case of using a conduit system (with NPT thread) instead of a cable gland the regulations of the country, where the unit is installed, must be observed. The conduit must have a tapered thread either NPT 1/2" or NPT 3/4" in accordance with the unit and ANSI B 1.20.1. Not used inlets must be closed tight with a metal closing element.
Field wiring cables	<ul style="list-style-type: none"> • The diameter has to match to the clamping range of the used cable gland. • The cross section has to match with the clamping range of the connection terminals and consider the max. current. • All field wirings must have insulation suitable for at least 250V AC. • The temperature rating must be at least 90°C (194°F). • If higher immunity interferences as specified in the stated EMC standards are present (see chapter approval), a shielded cable is required, otherwise an unshielded instrumentation cable is satisfactory.
Connecting the terminals	Make sure that max. 8 mm (0.31") of the pigtailed are bared (danger of contact with live parts).
Guiding the cables in the terminal box	Cut the field wiring cables to appropriate length to fit properly into the terminal box.
Relay and transistor protection	Provide protection for relay contacts and output transistors to protect the device against inductive load surges.
Protection against static charging	The housing of the unit (and for the version with separate housing also the vibrating fork part) must be grounded to avoid static charging of the unit. This is particularly important for applications with pneumatic conveying and non-metallic containers .

Electrical installation

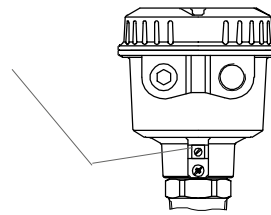
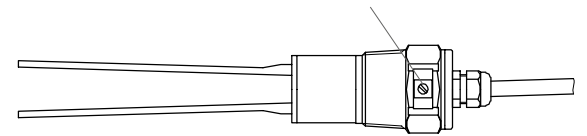

Additional Safety Instructions for Hazardous Locations

Installation in Zone 20	If installing the whole unit in zone 20, the power supply shall be rated for a prospective short circuit current of not more than 10 kA. Details of EN 60079-14/ ABNT NBR IEC 60079-14 must be obeyed.	
Installation in Zone 0 (Electronics: „NAMUR“ and “8/16mA or 4-20mA”)	The intrinsic safe supply circuit must have galvanic isolation to non intrinsic safe part. Otherwise measures for protection against lightning must be taken. See EN 60079-14/ ABNT NBR IEC 60079-14.	
Power supply (Electronics: „NAMUR“ and “8/16mA or 4-20mA”)	The type of protection (intrinsic safe) is only valid when connecting to a certified intrinsic safe power supply (associated apparatus).	
Field wiring terminals for “de” housing	Fixing torque : Remove wire isolation:	0,5-0,6 Nm 9 mm
Field wiring	A strain relief must be provided for the field wiring cables, when the device is installed with the factory provided cable glands.	
External equipotential bonding terminal	Connect with equipotential bonding to the plant	Version with separate housing must be grounded additionally at the vibrating fork.
		
Cable glands and conduit system for ATEX/ IEC-Ex/ TR-CU (Dust and Gas Hazardous Locations)	<p>Installation according to the regulations of the country, where the product is installed.</p> <p>Not used entries have to be closed with blanking elements certified for this purpose.</p> <p>Where available the factory provided parts must be used.</p> <p>A strain relief must be provided for the field wiring cables, when the device is installed with the factory provided cable glands.</p> <p>The diameter of the field wiring cable must match to the clamping range of the cable clamp.</p> <p>If other than the factory provided parts are used, following must be ensured: The parts must have an approval adequate to the approval of the level sensor (certificate and type of protection). The approved temperature range must be from the min. ambient temperature of the level sensor to the max. ambient temperature of the level sensor increased by 10 Kelvin. The parts must be mounted according to the instructions of the supplier.</p> <p>Installation of a flameproof/ explosion proof enclosure with a conduit system: In a conduit system single electric conductors are installed in a certified pipe system. This pipe system is in a flameproof/ explosion proof construction as well. The flameproof/ explosion proof enclosure and the pipe system needs to be sealed from each other by a certified flameproof seal of a type “d” or explosion proof of a type “XP”. This seals shall be installed directly in or at the conduit entries of the flameproof/ explosion proof enclosure. Not used entries have to be closed with blanking elements certified for this purpose (flameproof type “d” or explosion proof type “XP”).</p>	

Electrical installation

Conduit system for FM and CSA

(Dust and Gas Hazardous Locations)

General requirements:

In addition the regulations of the country must be observed. The used flameproof seals and blanking elements must have an adequate type approval and a temperature range of at least -40°C (-40°F) to $+80^{\circ}\text{C}$ (176°F). In addition they shall be suitable for the conditions and correctly installed. Where available the provided original parts of the manufacturer must be used.

Installation of a flameproof enclosure “d” with a conduit system:

In a conduit system single electric conductors are installed in a certified pipe system. This pipe system is in a flameproof construction as well. The flameproof enclosure “d” and the pipe system needs to be sealed from each other by a certified flameproof seal. Conduit entries of a flameproof enclosure “d” shall have installed the flameproof seal within 18 inches from the enclosure wall. Not used entries have to be closed with adequate blanking elements of a certified flameproof type AEx Cl.1 Div.1 A.

Commissioning

Commissioning only with closed lid.

Exception: Units with protection method Intrinsic safety (“NAMUR” and “8/16 mA or 4-20 mA”)

Opening the lid

Units with flameproof GasExplosion approval (d-housing):

To prevent ignition of hazardous atmospheres, do not remove the lid (cover) while circuits are alive.

Units with Dust Explosion approval:

Before opening the lid ensure, that no dust deposits or cloudss are present.
 Do not remove the lid (cover) when the power is live.

Units with protection method Intrinsic safety (“NAMUR” and “8/16 mA or 4-20 mA”):

The lid can be removed when the power is live.

Electrical installation

Connection

VN 1000/ 2000: Standard-housing

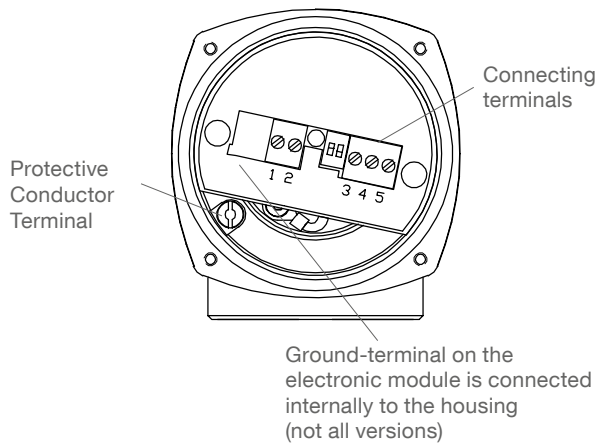

VN 5000/ 6000: Standard- and d-housing

Connection is done directly on the Electronic module

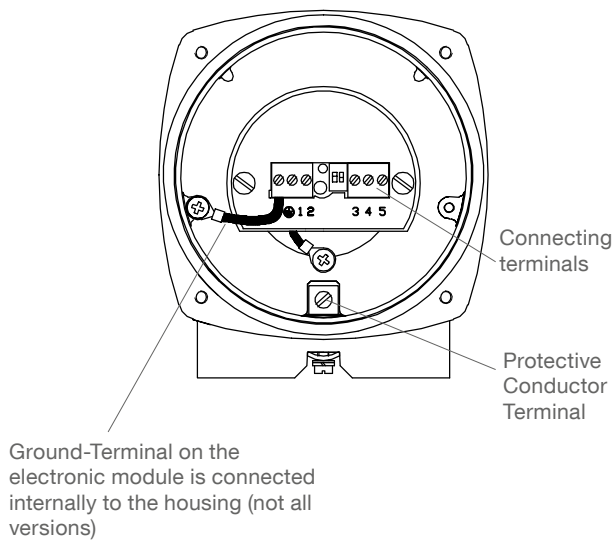

de-housing

Connection via the terminals inside the increased safety area.

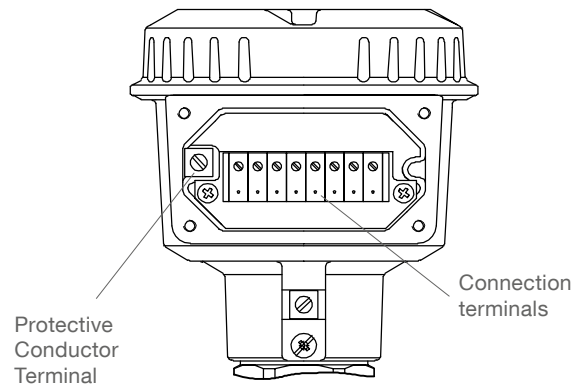

Electrical installation

Universal voltage

Relay SPDT

Power supply:

19 .. 230V 50 - 60 Hz +10% 8 VA
 19 .. 55 V DC +10% 1.5 W

Signal output:

Floating relay SPDT

VN 1000/ 2000:

AC max. 253 V, 4 A, 500 VA at cos Phi = 1
 DC max. 253 V, 4 A, 60 W

VN 5000/ 6000:

AC max. 250 V, 8 A, non inductive
 DC max. 30 V, 5 A, non inductive

Fuse on signal output: max. 10 A,
 slow or fast, HBC, 250 V

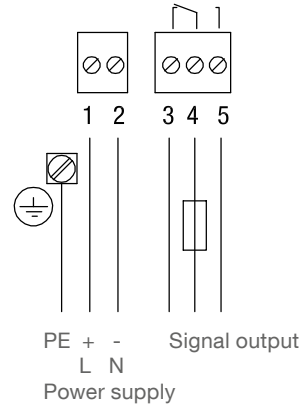

Universal voltage

Relay DPDT

Power supply:

19 .. 230 V 50 - 60 Hz +10% 18 VA
 19 .. 55 V (36 V*) DC +10% 2 W

Signal output:

Floating relay DPDT

VN 1000/ 2000:

AC max. 253 V, 4 A, 500 VA at cos Phi = 1
 DC max. 253 V, 4 A, 60 W

VN 5000/ 6000:

AC max. 250 V, 8 A, non inductive
 DC max. 30 V, 5 A, non inductive

Fuse on signal output: max. 10 A,
 slow or fast, HBC, 250 V

* Version with intrinsic safe connection
 between electronic module and vibration
 fork (see pos.4 in the selection list)

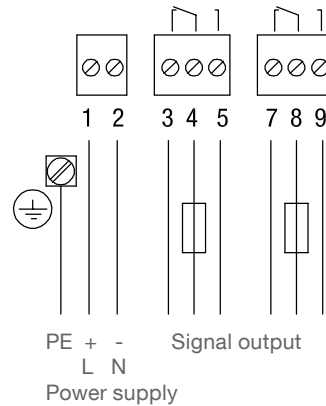

3-wire

PNP

Power supply:

18 .. 50 V DC +10% 1.5 W

Fuse: max. 4 A, slow or fast, HBC, 250 V

Signal output:

max. 0.4 A

Load for example:

PLC, relay, contactor, bulb

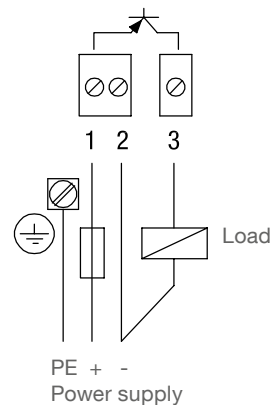

Electrical installation

2-wire without contact

Power supply:
 19 .. 230 V 50/60 Hz +10% 1.5 VA
 19 .. 230 V DC +10% 1 W

Load:
 min. 10 mA
 max. 0.5 A permanent
 (detailed ratings see
 "Technical data")

Load for example:
 relay, contactor, bulb

Fuse: max. 4 A, slow or fast, HBC, 250 V

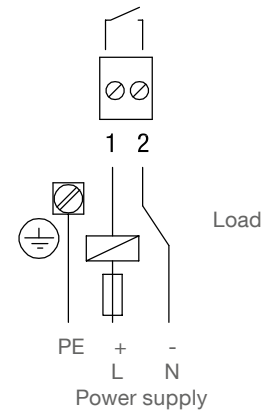

NAMUR IEC 60947-5-6

Power supply:
 ca. 7 .. 9 V DC
 intrinsic safe
 (spec. IEC 60947-5-6)

<1 mA or > 2.2 mA
 (spec. IEC 60947-5-6)

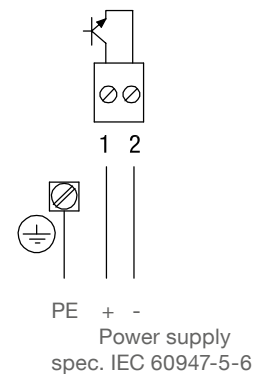

8/16mA or 4-20mA

Power supply:
 Non intrinsic safe version:
 12.5 .. 36 V DC +0%

Intrinsic safe version:
 12.5 .. 30 V DC +0%

Signal output
 Setting 8/16 mA:
 8 mA or 16 mA

Setting 4-20 mA:
 Output current depends on the vibration
 amplitude of the fork: 6mA for dampened
 vibration and 20 mA for full vibration.

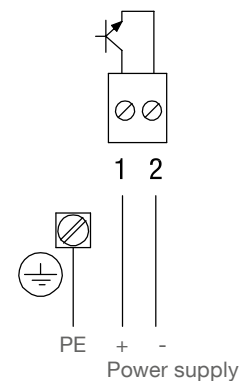

8/16mA

Power supply:
 12.5 .. 36 V DC +0%

Signal output
 8 mA or 16 mA

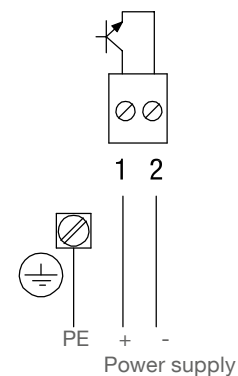

Signal output

Electronic modules:

Universal voltage
 (Relay SPDT and DPDT)

3-wire
 PNP

2-wire
 without contact

8/16mA

NAMUR
 (IEC 60947-5-6)

FSL/ FSH or Characteristic Setting

Remark: „FSH/ FSL“ is used for electronic modules:
 Universal voltage, 3-wire, 2-wire
 "Characteristic" is used for electronic module:
 NAMUR

FSH



If the sensor is used to indicate full load, set to Fail Safe High or Falling Characteristic. Power failure or line break is regarded as „full“ signal (protection against overcharging).

FSL



If the sensor is used to indicate empty load, set to Fail Safe Low or Rising Characteristic. Power failure or line break is regarded as „empty“ signal (protection against running dry).

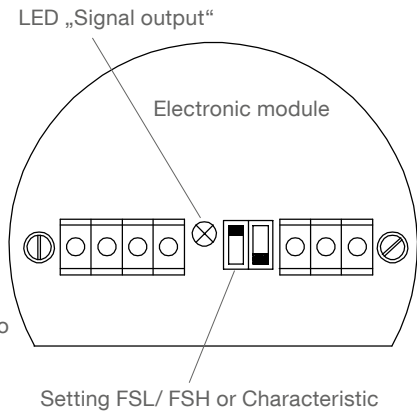

Signal output

Setting	FSL	FSH
Relay SPDT		
Relay DPDT		
3-wire PNP		
2-wire without contact		
8/16mA	I = 16 mA	I = 8 mA
LED „Signal output“		

Signal output

Setting	FSL	FSH
Relay SPDT		
Relay DPDT		
3-wire PNP		
2-wire without contact		
8/16mA	I = 8 mA	I = 16 mA
LED „Signal output“		

Setting	FSL	FSH
NAMUR IEC 60947-5-6		
LED „Signal output“		

Setting	FSL	FSH
NAMUR IEC 60947-5-6		
LED „Signal output“		

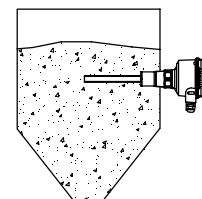
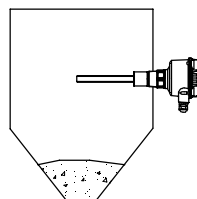

Signal output delay / Diagnosis

Signal output delay

Electronic module
Universal voltage
 (Relay DPDT)

Signal output delay

The signal output can be delayed, adjustable from 0 up to ca. 30 seconds. Clockwise turning of the potentiometer increases the delay time.

Potentiometer T1:
 Delay when output switches from sensor covered -> free

Potentiometer T2:
 Delay when output switches from sensor free -> covered

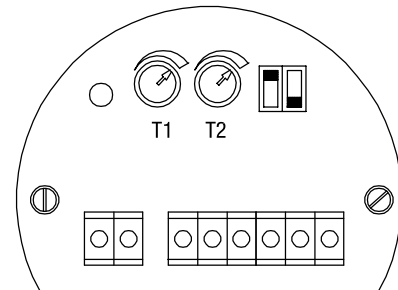

Diagnostics

Electronic module
NAMUR
 (IEC 60947-5-6)

“TEST” Button

If the sensor is not covered with material:
 By pressing this button, the vibration will stop and the signal output will switch to indicate “covered sensor”. This allows to test the vibration and the electronics for function without removing the sensor from the silo.

Remark: By pressing the button, the internal signal from the piezo-element, that indicates the vibration of the fork, is shortened. The electronics miss the vibration signal and indicates “covered sensor”.

If the sensor is covered with material:
 Pressing of this button has no effect.

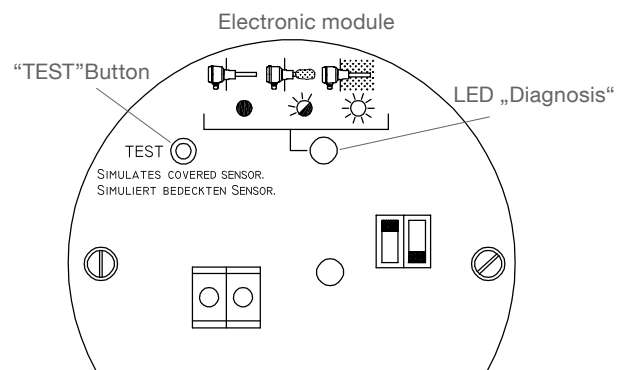

Weak vibration Diagnosis: LED “Diagnosis”

The quality of the measurement is related to the vibration amplitude of the sensor and can be evaluated by the internal LED „Diagnostics“ as follows:

- **Safe measurement, clean fork (LED is off):**
 The vibration amplitude is strong. There is enough safety to the switching point.
- **Weak vibration amplitude (LED is blinking):**
 The sensor is still working but it can happen that gradually the amplitude decreases further (maybe by increasing material build up) and the measurement fails. If low vibration amplitude is indicated the sensitivity setting should be changed from „20g/l“ to „75 g/l“ (or from „5g/l“ to „20g/l“ on version with enhanced sensitivity) if material density is not too low and the fork should be cleaned from material. Remark: By shifting the setting to “75g/l” (or to „20g/l“ on version with enhanced sensitivity), the internal amplification of the vibration signal in the electronic is increased. This allows more build up of material.
- **Fork fully covered (LED is on):**
 The sensor is fully covered with material. The vibration has stopped.

Signal output and Diagnosis

Electronic module
8/16 mA or 4-20 mA

The output can either be set to give 8/16 mA or to give 4-20 mA. On setting 4-20 mA the output depends on the amplitude of the vibration of the fork.

Characteristic setting

▼ If the sensor is used to indicate full load, set to Falling Characteristic. Power failure or line break is regarded as „full“ signal (protection against overcharging).

▲ If the sensor is used to indicate empty load, set to Rising Characteristic. Power failure or line break is regarded as „empty“ signal (protection against running dry).

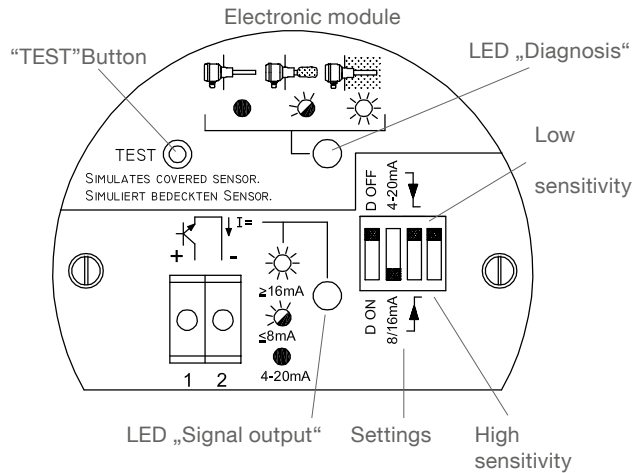

	Low sensitivity	High sensitivity
VN 1000/ 5000	150 g/l (9 lb/ft ³)	50 g/l (3 lb/ft ³)
VN 2000/ 6000	75 g/l (4,5 lb/ft ³)	20 g/l (1.2 lb/ft ³)
VN 2000/ 6000 with enhanced sensitivity	20 g/l (1.2 lb/ft ³)	5 g/l (0.3 lb/ft ³)

Weak vibration diagnosis

The quality of the measurement is related to the vibration amplitude of the sensor and can be evaluated by the output current and by the internal LED „Diagnosis“ as follows:

- **Safe measurement (clean fork):**
The vibration amplitude is strong. There is enough safety to the switching point.
- **Weak vibration amplitude:**
A fork with so much material build up, that a weak vibration amplitude is indicated. The sensor is still working, but it can happen, that gradually the amplitude decreases further (maybe by increasing material build up) and the measurement fails. If low vibration amplitude is indicated, the sensitivity setting should be changed from „High sensitivity“ to „Low sensitivity“, if material density is not too low, and the fork should be cleaned from material. Remark: By shifting the setting to „Low sensitivity“, the internal amplification of the vibration signal in the electronic is increased. This allows more build up of material.
- **Fork fully covered:**
The sensor is fully covered with material. The vibration has stopped.

“TEST” Button

If the sensor is not covered with material:

By pressing this button, the vibration will stop and the signal output will switch to indicate “covered sensor”. This allows to test the vibration and the electronic for function without removing the sensor from the silo.

Remark: By pressing the button, the internal signal from the piezo-element, that indicates the vibration of the fork, is shortened. The electronic misses the vibration signal and indicates “covered sensor”.

If the sensor is covered with material:

Pressing of this button has no effect.

Factory provided settings

- D OFF
- 8/16 mA
- ▼
- High sensitivity

Signal output and Diagnosis

Electronic module
8/16 mA or 4-20 mA

Output setting: 8/16 mA

The figure illustrates the output current depending on the situation with:

- Safe measurement (clean fork).
- Weak vibration amplitude: a fork with so much material build up, that a weak vibration is indicated.
- Fork fully covered.

The output current can indicate the weak vibration with diagnostics setting „D ON“.

Diagnosis off (setting „D OFF“):

The output changes between 8 mA and 16mA.

Diagnosis on (setting „D ON“):

The output will change from 16 mA to 20 mA and from 8 mA to 6 mA, if the vibration is weak. This enables an evaluation on an external 4-20 mA power supply. There is an internal delay of 10 seconds, until the change from 16mA to 20 mA and from 8 mA to 6 mA happens, so that the external power supply does not indicate „weak vibration“, when the vibration is stopped and is started during normal (safe) measurement operation.

	Clean fork		Fork with material build up		Fork fully covered	
Characteristic setting	↓	↑	↓	↑	↓	↑
D setting	D ON	I= 16 mA	I= 8 mA	I= 16 mA	I= 8 mA	I= 16 mA
				I= 20 mA	I= 6 mA	
LED „Signal output“	☀	●	☀	●	●	☀
LED „Diagnosis“	●	☀	☀	●	☀	☀

Example of evaluating the diagnosis of weak vibration amplitude:

Connection of an external Limit Value Monitor with 4-20 mA input and two relay outputs.
 (Fitting units can be ordered as accessories, see price list)

Relay 1 indicates the situation: Full/ empty.

Relay 2 works as a diagnostics output to indicate: Safe measurement/ Non safe measurement (weak vibration).

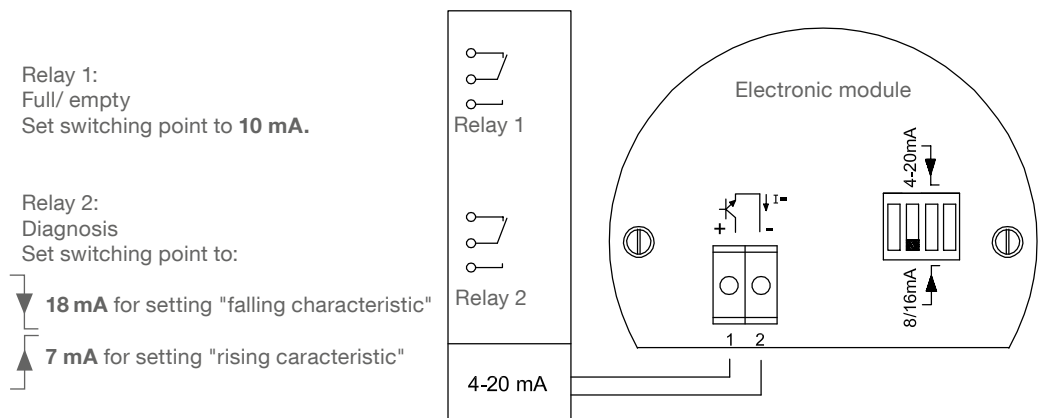

External Limit Value Monitor with 4-20 mA input and two relay outputs.

Signal output and Diagnosis

Electronic module Output setting: 4-20 mA
8/16 mA or 4-20 mA

The output states the quality of the vibration signal (amplitude) of the sensor. With the 4-20 mA setting it is possible, to recognize material build up on the vibrating fork by evaluation with a PLC. Furthermore it is possible to evaluate the vibration behaviour for critical applications by using a 4-20 mA Data logger or PLC.

Remark

In this mode:

- The switch „D ON“ or „D OFF“ has no influence.
- The LED „Signal output“ is off.

Output current:

- **20 mA:**
The vibration amplitude is strong (safe measurement, clean fork). With interface measurement (VN 10..0 und VN 50..0) a max. vibration amplitude of approx. 15 mA occurs.
- **< 20mA and >12/ 12.5mA:**
The vibration amplitude is decreased by material build up or mechanical influence. On setting „Low sensitivity“ the material build up must be more to decrease the output current compared to setting „High sensitivity“.
- **<12/12.5 mA and >7/8 mA:**
The recommended range indicate a weak vibration. This is also the range, where the internal LED „Diagnosis“ starts blinking to indicate a weak vibration. Depending on the application this value can be changed in the PLC.
The evaluation in the PLC should be done so, that a window between 12/12.5 mA and 7/8 mA is set. The reaction to indicate „weak vibration“ should be delayed for approx. 10 seconds, so that the indicator does not happen when the vibration is stopped and is started during normal and safe measurement operation.
A lag of 0.5 mA (between 12 mA and 12.5 mA) should be considered to avoid jittering of the output.
- **7/8 mA:**
The recommended point to indicate a covered sensor. The point is close to the stop of the vibration at 6 mA. Depending on the application this point can be changed in the PLC.
A delay of 1 mA (between 7mA and 8mA) should be considered to avoid jittering of output.
- **6 mA:**
The vibration has fully stopped.

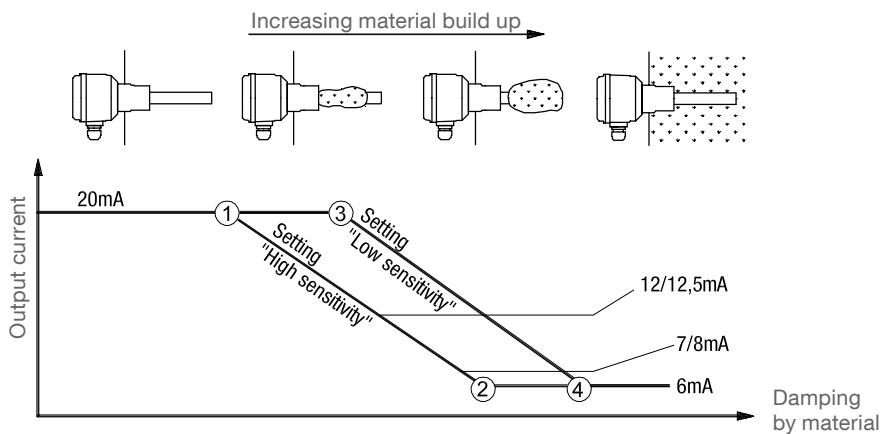

With setting „High sensitivity“:

- ① Amplitude is 100%
- ② Amplitude is 0%

With setting „Low sensitivity“:

- ③ Amplitude is 100%
- ④ Amplitude is 0%

Setting: Sensitivity

All Electronic modules

Sensitivity

All sensors are factory preset. Normally it is not necessary to change the settings. If the bulk material has a strong tendency to cake or deposit the setting switch can be set to position „A“ to decrease the sensitivity of the probe (factory presetting = position „B“).

Approximate min. bulk density on setting:

	A Low sensitivity	B High sensitivity
VN 1000/ 5000	150 g/l (9 lb/ft ³)	50 g/l (3 lb/ft ³)
VN 2000/ 6000	75 g/l (4.5 lb/ft ³)	20 g/l (1.2 lb/ft ³)
VN 2000/ 6000 with enhanced sensitivity	20 g/l (1.2 lb/ft ³)	5g/l (0.3 lb/ft ³)

VN 1000/ 5000:

For measurement of solids in water setting „A“ is recommended or to take the electronic with potentiometer.

Option interface measurement

(Sensitivity adjustable with potentiometer)

Turn to Min: Vibrating fork gets less sensitive

Turn to Max: Vibrating fork gets more sensitive

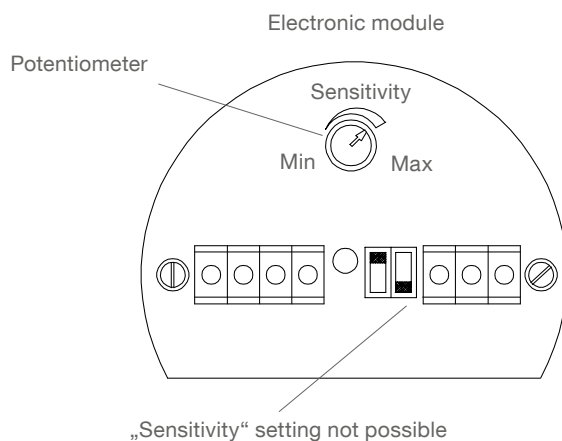
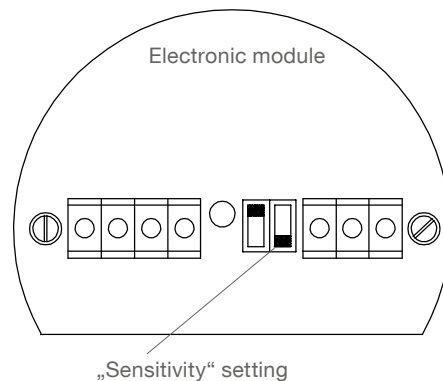

Maintenance

Opening the lid (cover) Before opening the lid for maintenance reasons observe following items:

- Do not remove the lid while circuits are alive.
- No dust deposits or whirlings are present.
- No rain can enter into the housing.

Frequent check of the unit Frequent check of the unit
 To ensure durable safety in hazardous locations and with electrical safety, following items must be checked frequently depending on the application:

- Mechanical damage or corrosion of any components (housing side and sensor side) and of the field wiring cables.
- Tight sealing of the process connection, cable glands and enclosure lid.
- Properly connected external PE cable (if present).

Cleaning **Cleaning**
 If cleaning is required by the application, following must be observed:

- Cleaning agent must comply with the materials of the unit (chemical resistance). Mainly the lid sealing, cable gland and the surface of the unit must be considered.

The cleaning process must be done in a way, that:

- The cleaning agent cannot enter into the unit through the lid sealing or cable gland.
- No mechanical damage of the lid sealing, cable gland or other parts can happen.

Units with EHEDG certification, which are used in the respective EHEDG applications, must be cleaned dry only (Type ED). Furthermore the respective regulations must be observed.

A possible accumulation of dust on the unit does not increase the maximum surface temperature and must therefore not be removed for purposes of maintaining the surface temperature in hazardous locations.

Function test A frequent function test may be required depending on the application.

Observe all relevant safety precautions related with a safe work depending on the application (e.g. hazardous locations, hazardous bulk material, electric safety, process pressure).

This test does not proof if the sensor is sensitive enough to measure the material of the application.

Function test is done by stopping the vibration of the vibrating rods with appropriate means and monitor if a correct change of the signal output from uncovered to covered happens.

Production date The production date can be traced by the serial number on the typeplate. Please contact the manufacturer or your local distributor.

Spare parts All available spare parts are stated in the selection list

Changing the Electronic module

Intrinsic safe marked Electronic modules are not allowed to be exchanged with Electronic modules without Intrinsic safe marking. Observe warning labels inside the housing and Ex marking on the name plate.

1. Open the housing lid, remove the pigtails from the device.
2. Disconnect internal wire for earth connection (not on all versions).
3. Unscrew two fastening screws of the electronic module.
4. Pull out the Electronic module.
5. Insert a new Electronic module (until it locks into place) and tighten fastening screws.
6. Connect internal wire for earth connection (not on all versions).
7. Connect the pigtails to the device.

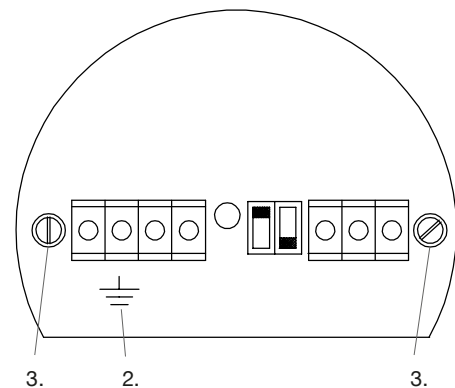

Repair of flamepath

Repair of flamepath on units with Ex d, Ex de or XP approvals is not intended.
 Please contact manufacturer.

Notes for use in Hazardous Locations

Zone classification

	usable in zone	ATEX category	IEC-Ex Equipment Protection Level (EPL)
Dust applications	20, 21, 22	1 D	Da
	21, 22	2 D	Db
	22	3 D *	Dc
Gas applications	0, 1, 2	1 G	Ga
	1, 2	2 G	Gb
	2	3 G	Gc

* in case of conductive dust additional requirements for the installation may be necessary

General Notes

Marking

Devices with Ex approval are marked on the name plate.

Process pressure



The device construction allows process over-pressure up to 6/ 16 bar (87/ 232 psi) (see name plate). These pressures are allowed for test purposes. The definition of the Ex approvals are only valid for a container-over-pressure between -0.2 .. +0.1 bar (-2.9 .. +1.45 psi). For higher or lower pressures the approvals are not valid.

Process and ambient temperature

The permitted temperature ranges are marked on the name plate.

Notes for use in Hazardous Locations

Permitted zones (categories) for mounting in partition wall

Version with standard-housing

(VN 1000/ 2000/ 5000/ 6000)

With use of Electronic module:

Universal voltage Relay SPDT
 Universal voltage Relay DPDT
 3-wire PNP
 2-wire without contact
 8/16 mA or 4-20 mA
 (non intrinsic safe)

NAMUR IEC 60947-5-6
 (intrinsic safe) *
 8/16 mA or 4-20 mA
 (intrinsic safe) *

EPL (IEC-Ex)	Da	Db	Da	Db	Ga	Gb **
Category (ATEX)	1D	2D	1D	2D	1G	2G **
Zone	20	21	20	21	0	1

EPL (IEC-Ex)	Da	Da	Da	Da	Ga	Ga
Category (ATEX)	1D	1D	1D	1D	1G	1G
Zone	20	20	20	20	0	0

* The units are marked on the name plate with "1G" and "1D" (ATEX) resp. "Ga" and "Da" (IEC-Ex). They can be also mounted in a partition wall with specification zone 0/1 and zone 20/21.

- ** VN ..040 and VN ..050:
 When mounting the units in a partition wall, that separates Zone 0 from Zone 1: The units have no safe separation between Zone 0 and Zone 1. It must be considered, that gas can pass from Zone 0 through the unit to Zone 1.

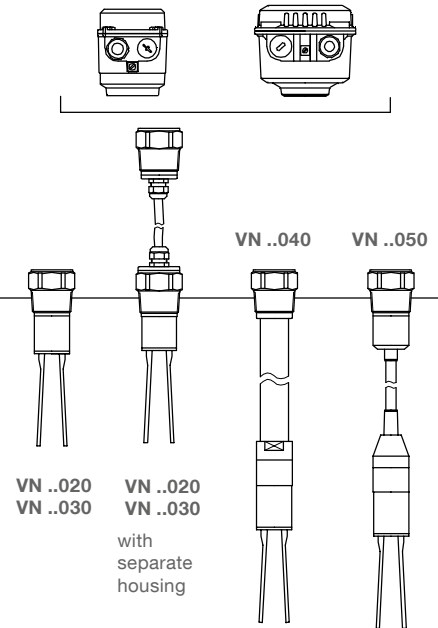

Version with d- and de-housing

(VN 5000/ 6000 ; flameproof/ increased safety)

With use of all Electronic modules:

EPL (IEC-Ex)	Gb	Db
Category (ATEX)	2G	2D
Zone	1	21

EPL (IEC-Ex)	Gb	Da
Category (ATEX)	2G	1D
Zone	1	20

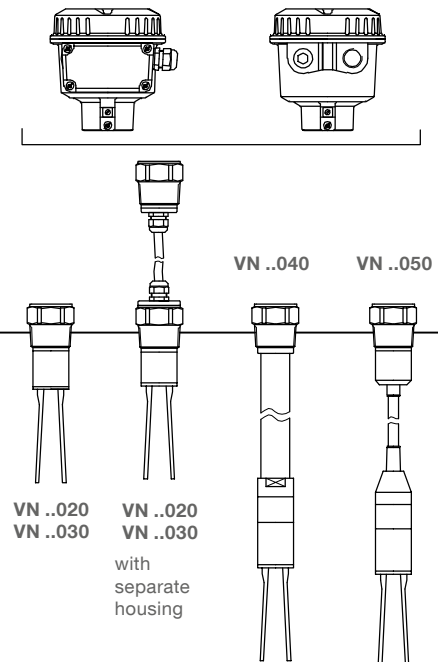

Notes for use in Hazardous Locations

Max. Surface Temperature and Temperature Class

The temperature marking on the name plate  refers to the instruction manual. On the following tables the relevant temperature ratings are shown.

The maximum surface temperature (resp. temperature class) is the warmest temperature of the unit which could occur during malfunction (according to Ex-definition).

The data tables are valid, when it can be guaranteed during installation that the screwed connection has a maximum temperature of 80°C (176°F) during normal use.

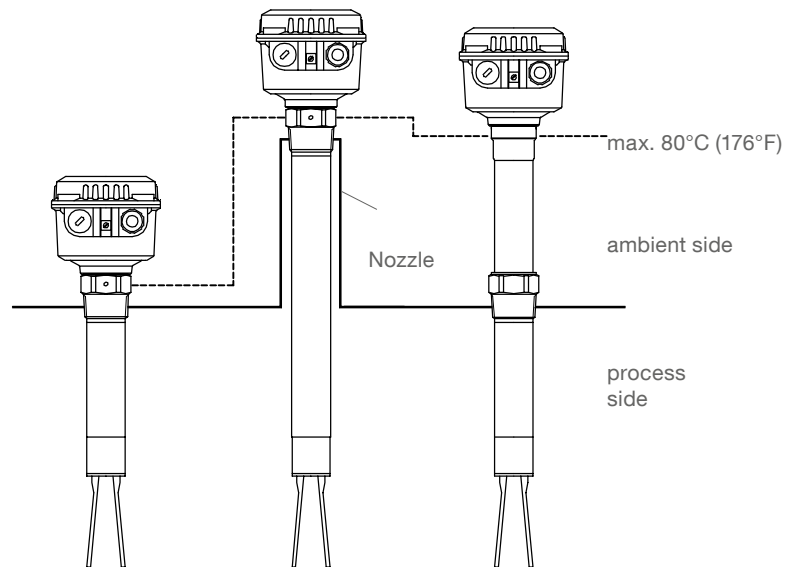

Versions with intrinsic safe electronic modules:
 NAMUR IEC 60947-5-6
 8/16 mA or 4-20 mA

Max. ambient temperature	Max. process-temperature	Max. surface temperature	Temperature class (Division System)	Temperature class (Zone System)
50°C (122°F)	70°C (158°F)	80°C (176°F)	T6	T6
60°C (140°F)	80°C (176°F)	85°C (185°F)	T6	T5
	90°C (194°F)	90°C (194°F)	T5	T5
	100°C (212°F)	100°C (212°F)	T5	T4
	110°C (230°F)	110°C (230°F)	T4A	T4
	120°C (248°F)	120°C (248°F)	T4A	T4
	130°C (266°F)	130°C (266°F)	T4	T4
	140°C (284°F)	140°C (284°F)	T3C	T3
	150°C (302°F)	150°C (302°F)	T3C	T3

Versions with non intrinsic safe electronic modules:
 Universal voltage Relay SPDT
 Universal voltage Relay DPDT
 3-wire PNP
 2-wire without contact
 8/16 mA or 4-20 mA

Max. ambient temperature	Max. process-temperature	Max. surface temperature	Temperature class (Division System)	Temperature class (Zone System)
60°C (140°F)	80°C (176°F)	120°C (248°F)	T4A	T4
	90°C (194°F)	120°C (248°F)	T4A	T4
	100°C (212°F)	120°C (248°F)	T4A	T4
	110°C (230°F)	120°C (248°F)	T4A	T4
	120°C (248°F)	120°C (248°F)	T4A	T4
	130°C (266°F)	130°C (266°F)	T4	T4
	140°C (284°F)	140°C (284°F)	T3C	T3
		150°C (302°F)	150°C (302°F)	T3C

Assembly VN ..040

Manufacturing of the Extension tube

! Obtain instruction manual for proper manufacturing of the extension tube. In case of deviation from the instruction manual the unit is not safe for use in Hazardous Locations.

Demands on the Extension tube

Material: Stainless steel 1.4301 (SS304) or 1.4305 (SS301) or 1.4571 (SS316Ti) or 1.4404 (SS316L)

The tube must be manufactured from one single piece. It is not allowed to weld two or more pieces together.

Carefully observe max. length, diameter, wall thickness, thread, tolerances as specified in the drawing.

All sharp edges must be removed to protect the cable and sealing rings.

Thread testing

Each thread must be tested with no-go ring gauge according to standard DIN ISO 228-1 (G1") (G-version) or ANSI B 1.20.1 (NPT 1") (NPT version)

Version with G1" (DIN ISO 228-1) thread (selection price list pos.5 A,L,M)

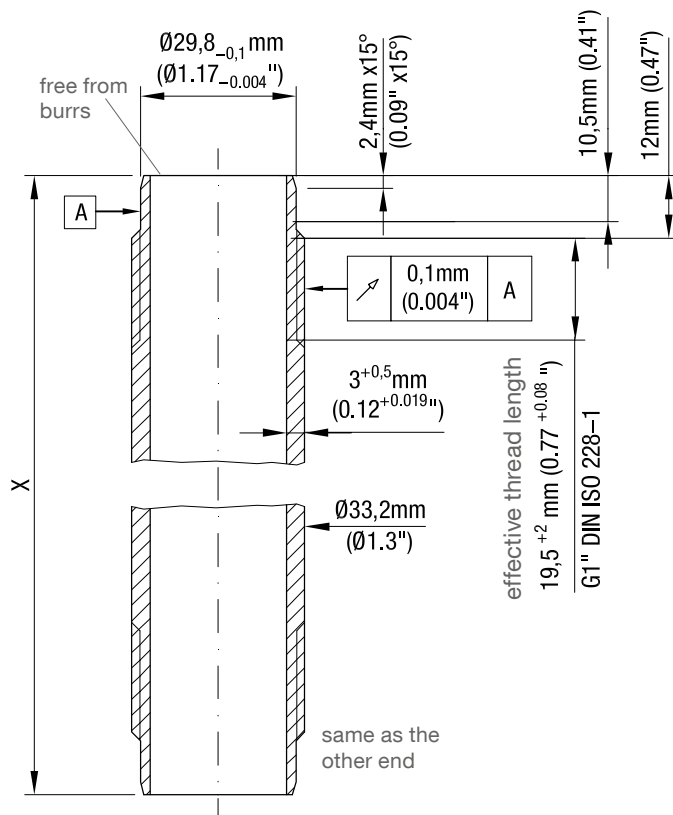

Pipe length X:

VN 1040: $X = L - 180 \text{ mm}$ ($X = L - 7.1''$)

VN 2040: $X = L - 250 \text{ mm}$ ($X = L - 9.8''$)

VN 2040 with pos.26 x,a,b: $X = L - 275 \text{ mm}$ ($X = L - 10.8''$)

Note: L is the total extension length

Version with 1" (ANSI B 1.20.1) NPT thread (selection price list pos.5 B,S,T,U)

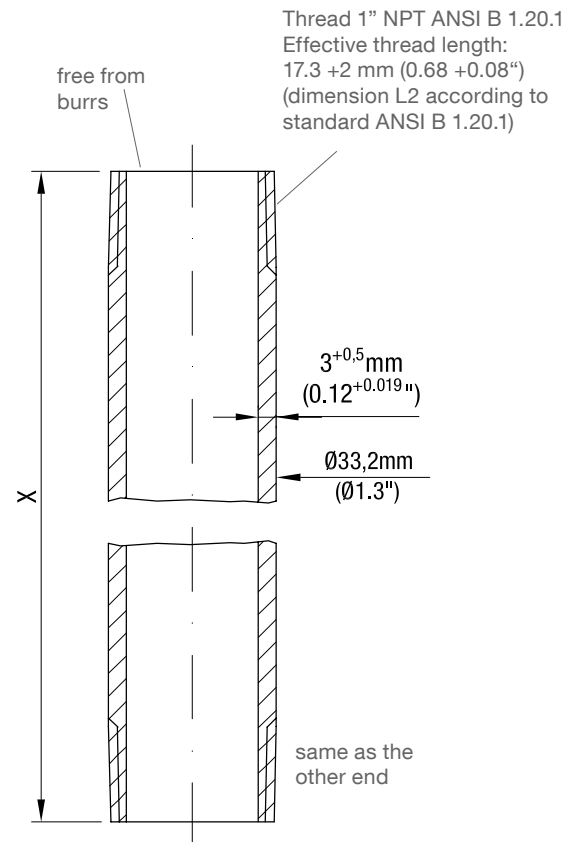

Pipe length X:

VN 1040: $X = L - 190 \text{ mm}$ ($X = L - 7.5''$)

VN 2040: $X = L - 260 \text{ mm}$ ($X = L - 10.2''$)

VN 2040 with pos.26 x,a,b: $X = L - 285 \text{ mm}$ ($X = L - 11.2''$)

Note: L is the total extension length

Assembly VN ..040 with standard housing

Assembly of the unit

1. Mounting of the Extension tube

- ! **The tube must be assembled very carefully to ensure permanent sealing and mechanical stability.**
- **Observe the follow mounting instructions.**

- ! **Make sure that the thread of the extension tube and the thread of the screwed piece/ oscillating piece is the same type (do not mix G and NPT thread).**

- 1.1. Feed the connecting wire through the 1" Extension tube and the screwed piece. Use a separate taut wire for easy working.
- 1.2. Screw the 1" Extension tube into the oscillating piece and the screwed piece.
 Tightening torque 50 Nm.
 Use a 36 mm (1.42") open-end wrench to attach the fork piece (do not use the forks).

G version: Tighten the 2 fixing screws.

Requirements for sealing:

There must be tight connections at both ends of the extension tube (IP67 or NEMA 4).

G version: An O-ring is required at both ends to ensure proper sealing and must not be damaged. Only original O-rings from the manufacturer are allowed to be used.

NPT version: The threads must be sealed with temperature resistant sealing for 150°C (302°F). Max. thickness of the sealing is 0.2 mm (0.008").

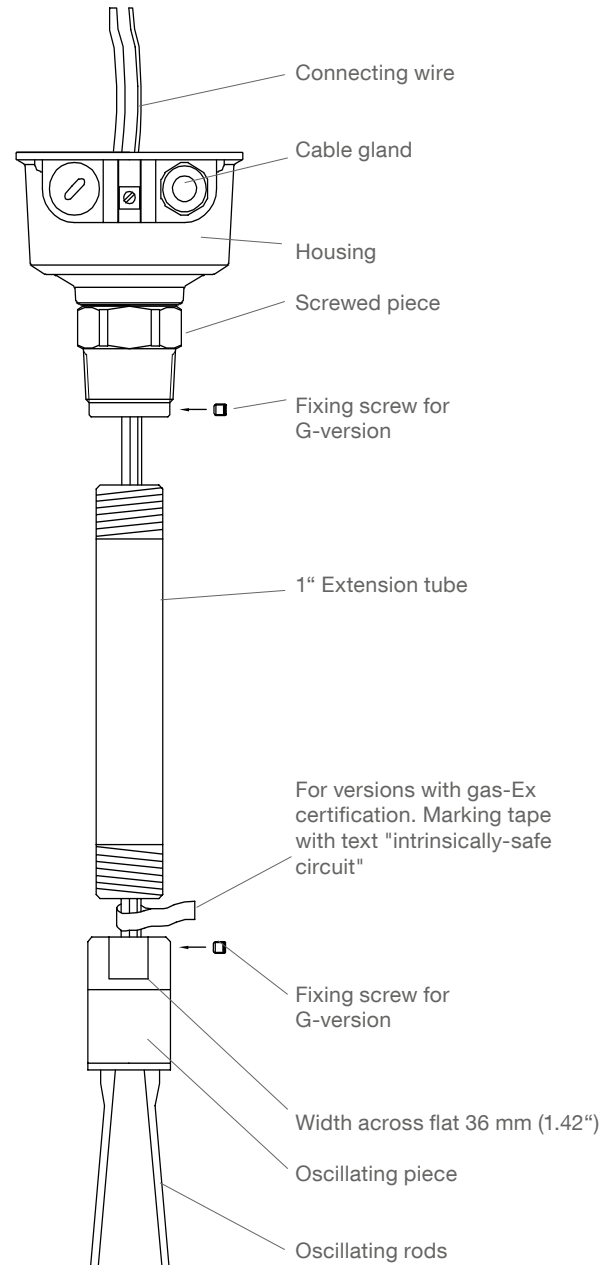

Assembly VN ..040 with standard housing

2. Preparing the cables

Shorten the earth cable to 220 mm (8.66") and sensor cables to 150 mm (5.9"). Prepare cables as shown.

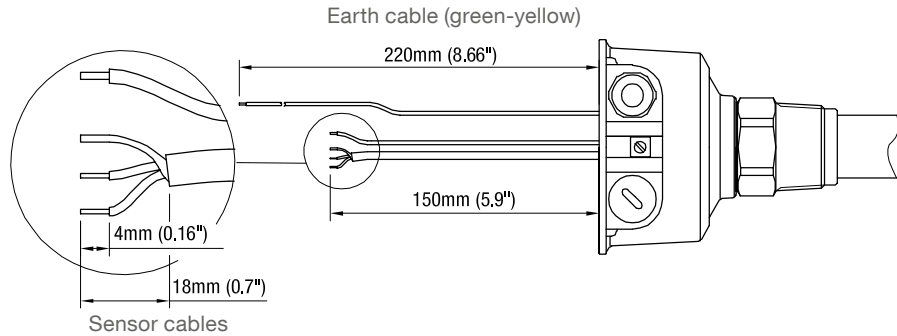

3. Connecting the cables

Connect sensor cables to the terminal connection piece. Fix the cables with cable clamps. Connect electronic module and terminal connection piece. Be sure that all terminals are tightly screwed in.

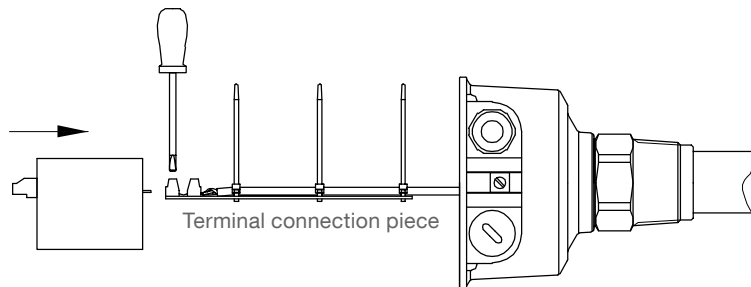

Take care that the non isolated shield wire (M) does not touch other metal parts (keep wire short or isolate with a hose)

Connect the earth cable from the vibrating fork to the housing (see figure at the bottom of this page).

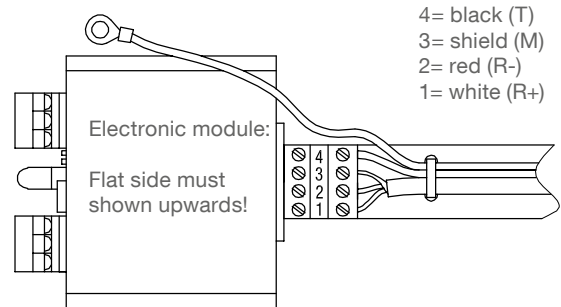

4. Fixing the electronic module

Insert electronic module into housing. The terminal connection piece is used to guide the cables. Fold connection cables as shown. Use cylinder head screws to fix the electronic module.

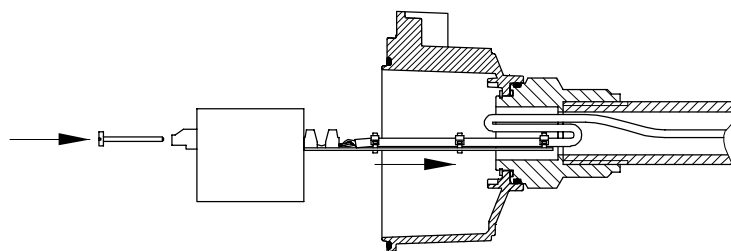

Connect the earth cable from the electronic module to the housing (not on all versions).

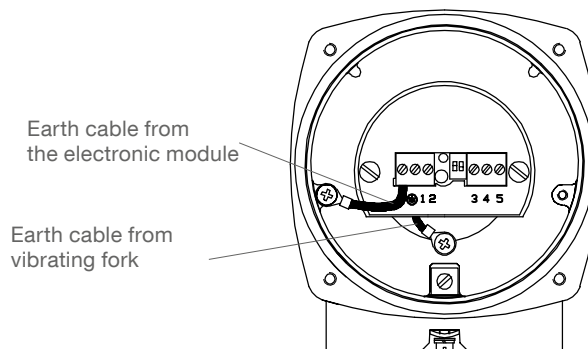

Assembly VN 5040/ 6040 with d or de-housing

Assembly of the unit

1. Mounting of the Extension tube to oscillating piece and preparing cables

● **The tube must be assembled very carefully to ensure permanent sealing and mechanical stability. Observe the follow mounting instruction.**

● **Make sure, that the thread of the extension tube and the thread of the screwed piece/ oscillating piece is the same type (do not mix G and NPT thread).**

1.1. Feed the connecting wire through the 1" Extension tube.
 Use a separate taut wire for easy working.

1.2. Screw the 1" Extension tube into the oscillating piece.
 Tightening torque 50 Nm.
 Use a 36 mm (1.42") open-end wrench, do not turn the oscillating rods.

G version: Tighten the Fixing screw

Requirements for sealing:

There must be a seal connection between the 1" tube and the screwed piece and the oscillating piece (IP67 or NEMA 4).

G version: An O-ring is required at both ends to ensure proper sealing and must not be damaged. Only original O-rings from the manufacturer are allowed to be used.

NPT version: The thread must be sealed with temperature resistant sealing for 150°C (302°F). Max. thickness of the sealing is 0.2 mm (0.008").

1.3. Shorten all cables to 80 mm (3.15"). Prepare cables as shown.

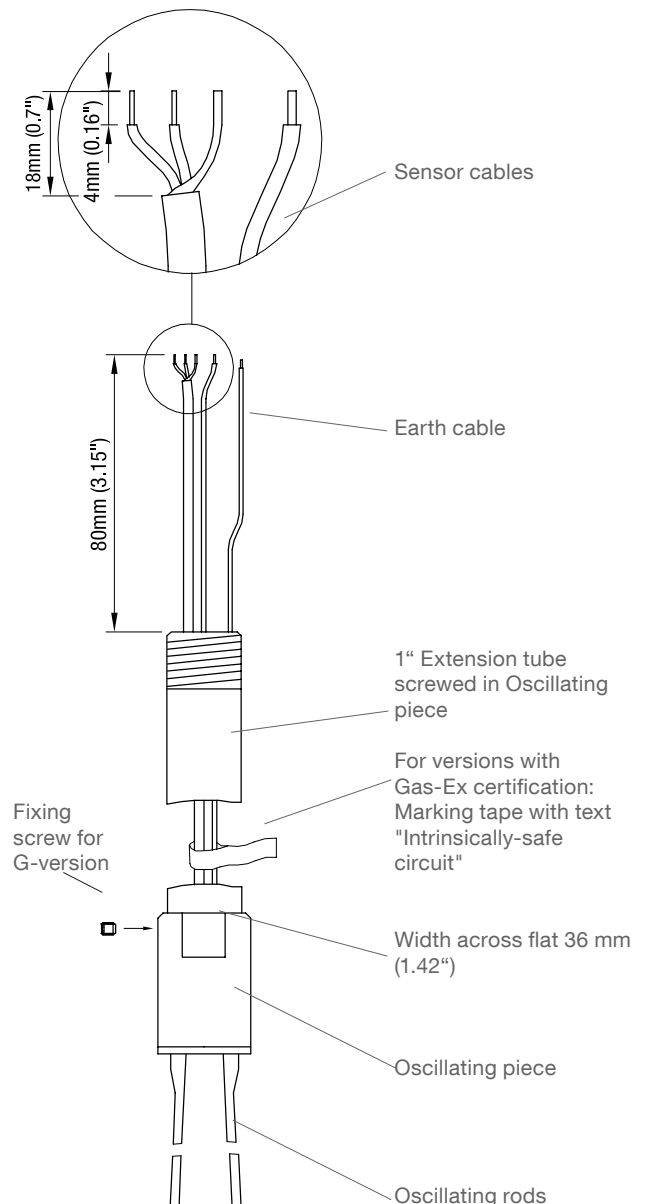

Assembly VN 5040 / 6040 with d or de-housing

2. Soldering the cables

Guide the big shrink hose over all cables.

Guide the small shrink hose over each cable.

Solder the cables as shown.

Shrink the small shrink hose with a hot air blower. Ensure that the exposed wires are all covered with shrink hose

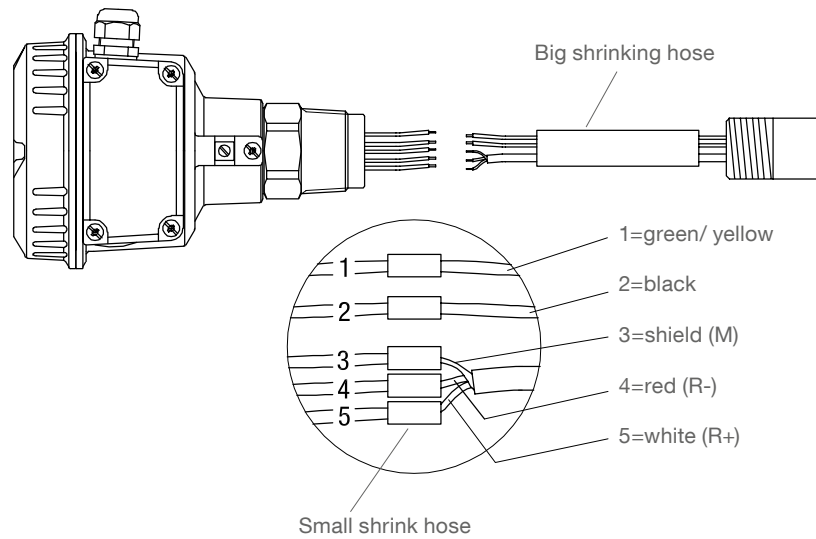

3. Shrinking all cables

Push the big shrink hose over the small shrink hoses and shrink with a hot air blower.

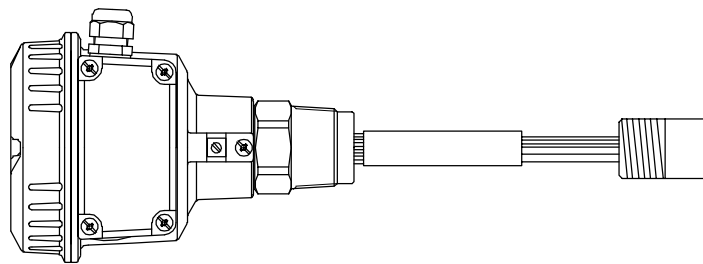

4. Mounting of the extension tube to housing side

Push the cables carefully into the extension tube.

Screw the 1" Extension tube into the screwed piece. Use a 36 mm (1.42") open-end wrench, do not turn the oscillating rods.

G version: Tighten the fixing screw

Sealing: see 1.2

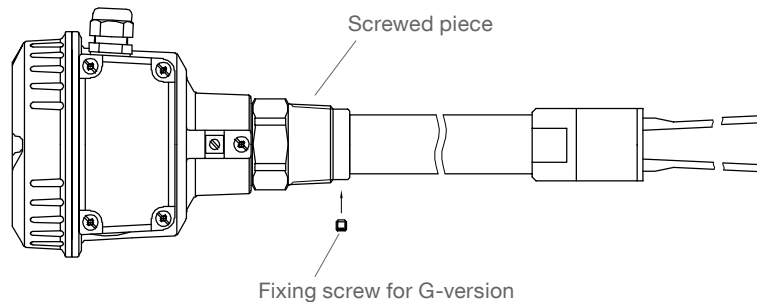

Assembly: VN ..020 / ..030 with separate housing

Remove and reassemble of the connection cable

The units with separate housing are factory delivered completely assembled.

Should it be required to remove the connection cable from the housing due to shortening the cable or leading the cable through a pipe or wall, observe following items.

Before planning to shorten the cable, check if it is possible to loop the cable between housing and oscillating piece (preferred solution).

! Remove the cable only on the housing side, never on the oscillating piece side.

! For reassembling observe following items:

- After cutting the cable, use the factory provided cable situation as a sample.
- Connect the outer shield of the connection cable to the cable gland.
- Obtain right connecting sequence on the plug (see drawing).
- Cut present cables, which are not required.
- Isolate the inner shield with an isolation hose to avoid that it may touch any other metal parts.
- Fix the electronic module into the housing with 2 screws. To do this, guide the connecting cable that it rests in the threaded bush and is not clamped between electronic module and housing. Take care, that the plug is not removing from the electronic module.

! The cable gland cable must be closed tightly to reach ingress protection IP67 or NEMA 4.

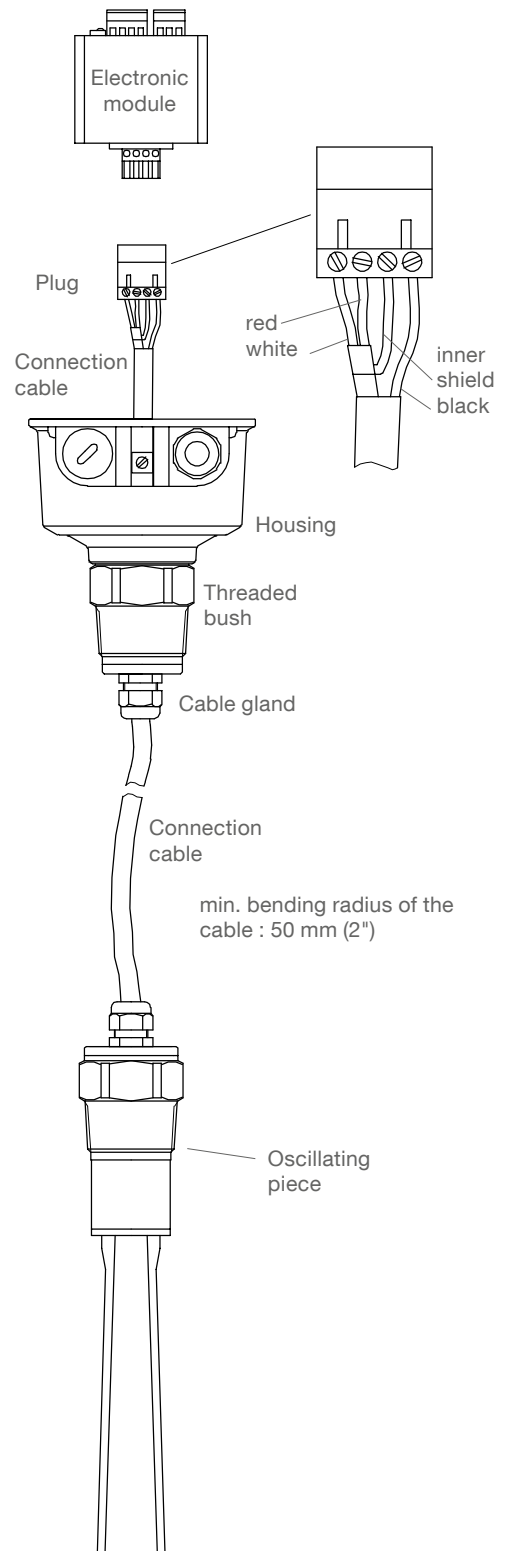

Assembly: VN ..020 / ..030 with separate d- or de- housing

Remove and reassemble of the connection cable

The units with separate housing are factory delivered completely assembled.

Should it be required to remove the connection cable from the housing due to shortening the cable or leading the cable through a pipe or wall, observe following items.

Before planning to shorten the cable, check if it is possible to loop the cable between housing and oscillating piece (preferred solution).

Remove the cable only on the housing side, never on the oscillating piece side.

For reassembling observe following items:

- After cutting the cable, use the factory provided cable situation as a sample.
- Connect the outer shield of the connection cable to the cable gland.
- Obtain right connecting sequence on the plug (see drawing).
- Cut present cables, which are not required.
- Isolate the inner shield with an isolation hose to avoid that it may touch any other metal parts.
- Connect plug and mating plug.
- Screw the tube into the threaded bush.
 Before screwing check that inside the threaded bush a seal ring is present which seals the tube to the threaded bush.
 While screwing, the cable gland must be open to avoid, that the connection cable is being twisted. Take care, that the plug is not removing from the mating plug.
- Fasten the two fixing screws.

The cable gland cable must be closed tightly to reach ingress protection IP67 or NEMA 4.

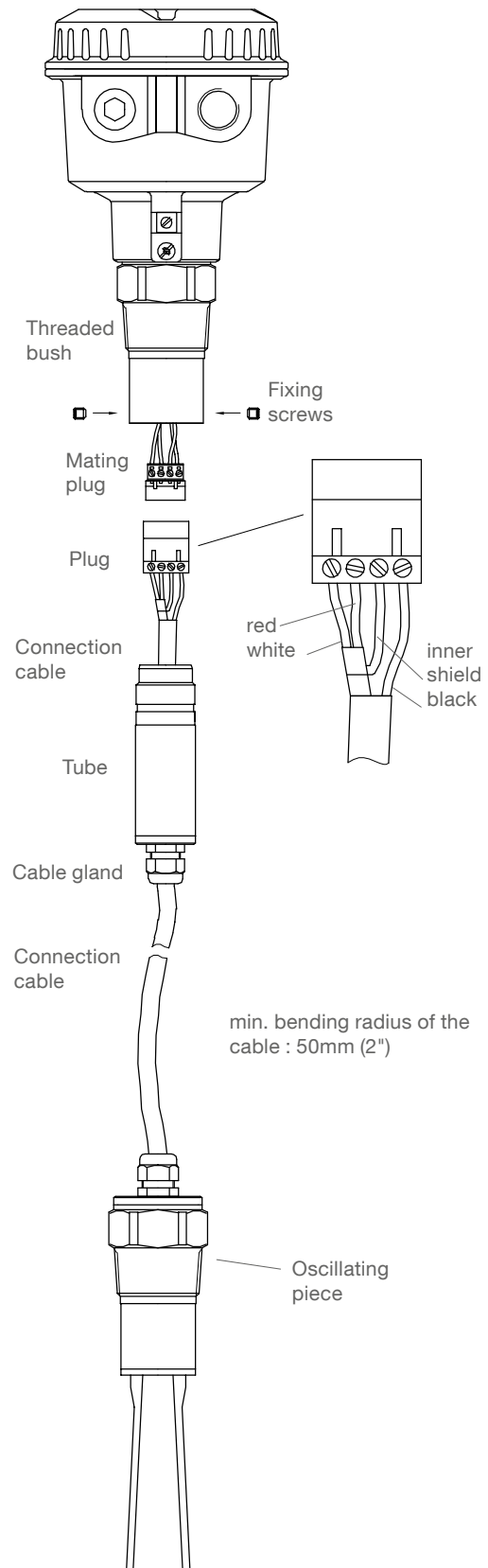

Disposal

The product consists of materials which can be recycled, details of the used materials see chapter "Technical data - mechanical data".

Recycling must be done by a specialised recycling company. Since the product is not subject to the WEEE directive 2002/96/EG, it is not permitted to bring it to a public recycling station.