

Table of contents

	Page
Safety notes/ Technical support	2

Introduction	3

Function	4

Technical data	5

Approvals	8

Options	9

Mounting	10

Electrical installation	12

Signal and Alarm output	15

Settings sensitivity	17

Maintenance	18

Notes for use in Hazardous Locations	19

Disposal	20

Subject to technical change
 All dimensions in mm (inches).

We assume no liability for typing errors.
 Different variations than specified are possible.
 Please contact our technical consultants.

Safety notes / Technical support

Notes

- Installation, maintenance and commissioning must be carried out only by qualified technical personnel.
- The product must be used only in the manner outlined in this instruction manual.

Special attention must be paid to warnings and notes as follows:

WARNING



Relates to a caution symbol on the product: A failure to observe the necessary precautions can result in death, serious injury and/ or considerable material damage.

WARNING



Relates to a caution symbol on the product: Risk of electric shock

WARNING



A failure to observe the necessary precautions can result in death, serious injury and/ or considerable material damage.

This symbol is used, when there is no corresponding caution symbol on the product.

CAUTION

A failure to observe the necessary precautions can result in considerable material damage.

Safety symbols

In manual and on product

Description



CAUTION: refer to accompanying documents (manual) for details.



Earth (ground) Terminal



Protective Conductor Terminal

Technical support

Please contact your local supplier (address details at www.uwt.de). Otherwise please contact:

UWT GmbH
 Westendstr. 5
 87488 Betzigau
 Germany

Tel. 0049-(0)831/ 57123-0
 Fax. 0049-(0)831/ 76879
info@uwt.de
www.uwt.de

Introduction

Applications

The ROTONIVO is an electromechanical Level limit switch and is used for level monitoring of bulk goods.

The units can be delivered with Ex-approvals for use in Hazardous Areas.

Selected applications:

- **building materials industry**
lime, styrofoam, moulding sand, etc.
- **plastics industry**
plastics granules etc.
- **timber industry**
- **chemical industry**
- **mechanical engineering**

The ROTONIVO is normally screwed into the lateral container wall so that it is level with the filling height to be registered and monitored.

The device can also be mounted from the top of the container. In this case an extension piece is used to mount the probe level with the height to be registered (full detector).

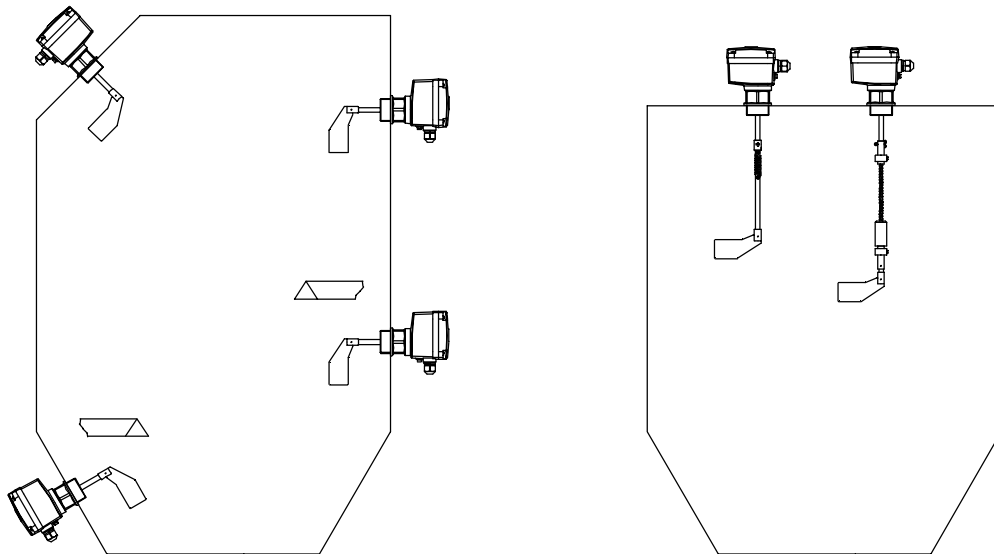

Function

A measuring vane is driven by a synchronous motor. The bearing of the motor inside the housing allows it to swing. The motor is fixed to a switching lug.

If the vane is uncovered, a spring pulls the motor and switching lug to the left position (figure 1).

When material covers the vane and thus stops the rotation, the motor and switching lug swings to the right position (figure 2). The signal output indicates "covered" and the motor is stopped.

When the vane becomes uncovered due to falling material, the spring pulls the motor and switching lug back to the left position (figure 1). The motor is started and the signal output indicates "uncovered".

Signal output delay

The version "universal voltage" and "PNP" has an integrated adjustable delay for the signal output.

Option fail safe alarm

With the fail safe alarm it is possible to recognize a fault of the unit in time and to initiate an alarm relay. The following faults are observed:

- Motor
- Gear
- Electronic for motor power supply
- Supply voltage failure
- Defect of the connecting wires

Switchable signal output (Fail safe high/ low)

With version "Universal voltage" and "PNP" a switchable signal output FSH/ FSL is integrated.

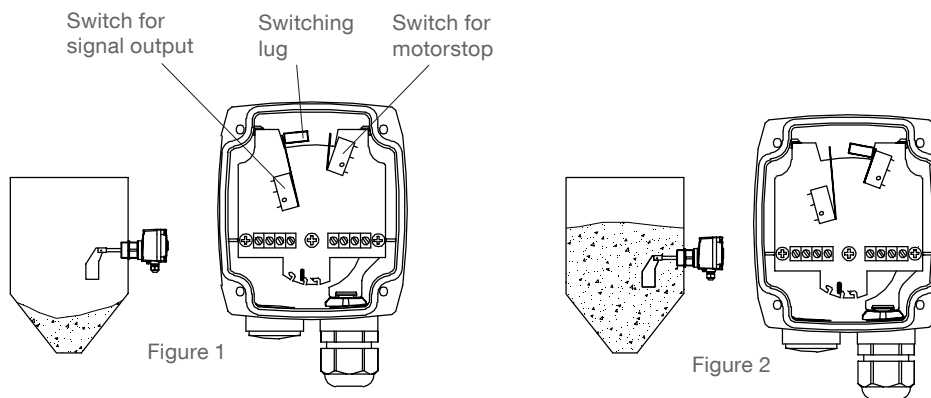

Electronics						
Supply		Signal output				
		SPDT ⁽¹⁾	PNP	FSH/ FSL ⁽²⁾	Adjust. delay	Fail safe alarm
AC version	24 V or 48 V or 115 V or 230 V AC	•	-	-	-	-
DC version	24 V DC	•	-	-	-	-
DC version	24 V DC PNP	-	•	•	•	-
Universal voltage	24V DC/ 22 .. 230 V AC	•	-	•	•	option

⁽¹⁾ Micro switch, Relais for universal voltage

⁽²⁾ Switchable signal output (Fail safe high/ low)

Technical Data

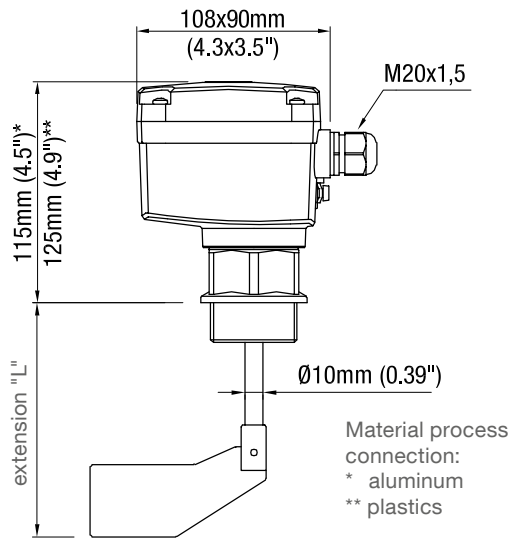

Measuring vanes

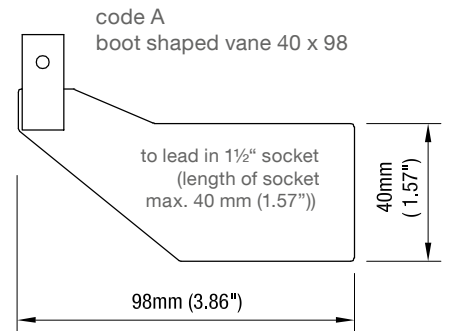

code K
 hinged vane 98 x 200
 double sided

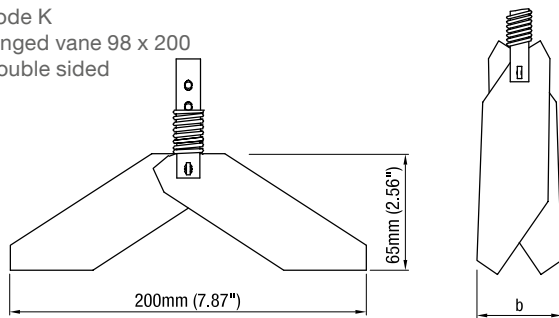

b=37 mm (1.46")
 for 1½"/ 1¼"

b=28 mm (1.1")
 for 1"/ M32 x 1.5

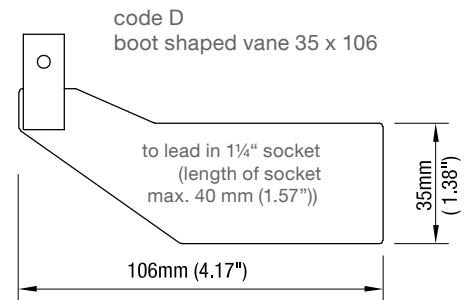

code S
 hinged vane 98 x 100
 single sided

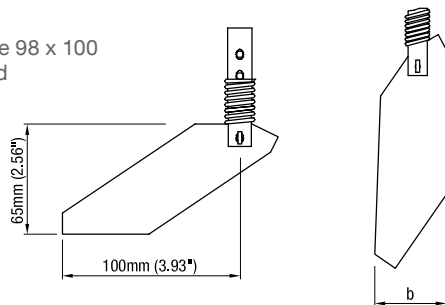

b=37 mm (1.46")
 für 1½"/ 1¼"

b=28 mm (1.1")
 for 1"/ M32 x 1.5

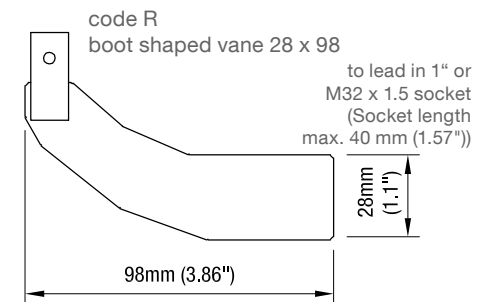

Insertion of the hinged vane through a long socket

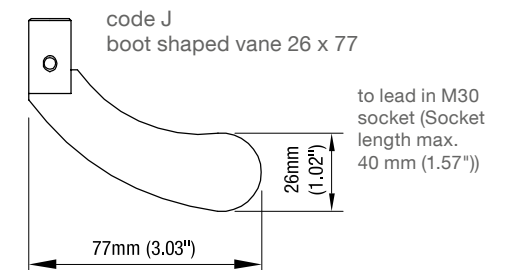
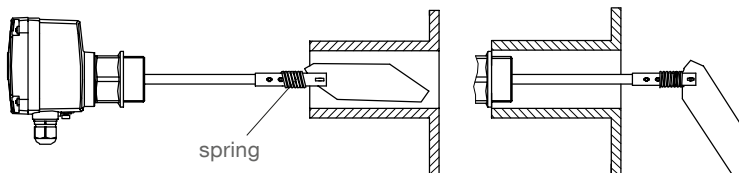

code U
 universal vane
 (plastics)

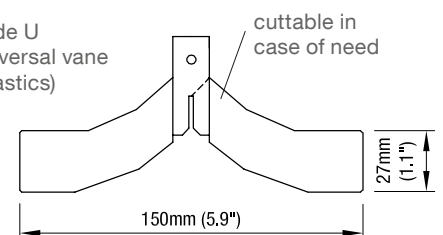

Technical Data

Electrical data

Connection terminals	max. 1.5 mm ² (AWG 16)
Cable entry	M20 x 1.5 screwed cable gland Clamping range (diameter) of the factory provided cable glands: M20 x 1.5: 6 .. 12 mm (0.24 .. 0.47")
Protection class	I III (Version 24V DC PNP)
Overvoltage category	II
Pollution degree	2 (inside housing)
Power supply	see page 14
Installed load	see page 14
Signal and alarm output	see page 14
Isolation	Power to signal and alarm output: 2,225 Vrms
Indicating light	By built-in LED (not with AC version)

Mechanical data

Housing	Plastics PA6 GF, RAL 5010 gentian blue Seal between housing and lid: NBR Seal between housing and process connection: NBR Nameplate: polyester film
Degree of protection	IP66 (IEC/EN/NBR 60529)
Process connection	Aluminium or plastics PA6 GF Thread: Metric or G (DIN 228) according to selection
Vane shaft and measuring vane	Material: stainless steel 1.4301 (304)/ 1.4305 (303), Universal vane in plastics PP
Tolerance length "L"	±10 mm (±0.39")
Bearing	Process connection aluminium: ball bearing, dust tight Process connection plastics: slide bearing (maintenance-free, high-quality)
Sealing	Radial rotary shaft sealing. Material: NBR (Acrylnitril-Butadien-rubber)
Friction clutch	Protects the gear unit against impacts of the measuring vane
Speed of measuring vane	1 rotation or 5 rotations per minute
Sound level	max. 50 dBA

Technical Data

Operating conditions

Ambient temp. (housing)	-20 .. +60°C (-4 .. +140°F) -40 .. +60°C (-40 .. +140°F) Version with heating of housing (pos.26)		
Process temperature	-20 .. + 80°C (-4 .. +176°F) -40 .. +80°C (-40 .. +176°F) Version with heating of housing (pos.26)		
Ventilation	Ventilation is not required		
Min. powder density/ Sensitivity	see section "Sensitivity" on page 17		
Signal delay	Version	AC, DC, Multivoltage	Universal voltage
	Sensor free -> covered*	ca. 1.3 sec	ca. 1.5 sec + 0 .. 20 sec adjustable
	Sensor covered -> free	ca. 0.2 sec	ca. 0.2 sec + 0 .. 60 sec adjustable
	*after blocking of the measuring vane		
Features of bulk material	Hardly any limitations		
Max. permitted mechanical torque (lateral)	Process connection aluminium:	max. 50 Nm	
	Process connection plastics:	max. 25 Nm	
	Protective measures in case of high loading: mounting of an protective canopy above the probe.		
Max. tractive force	Pendulum shaft:	400 N (applicable only as full detector)	
	Rope extension:	1.5 kN (applicable only as full detector)	
Max. process pressure	-0.9 .. +0.8 bar (-13.1 .. +11.6 psi) Versions with Ex-approvals: see remarks on page 19.		
Vibration	1.5 (m/s ²) ² /Hz according to EN 60068-2-64		
Relative Humidity	0 - 100%, suitable for outdoor use		
Altitude	max. 2,000 m (6,562 ft)		
Expected product lifetime	Following parameters have a negative influence on the expected product lifetime: High ambient- and process temperature, corrosive environment, high vibration, high flow rate of abradable bulk material passing the sensor element, high amount of measurement cycles.		

Transport and Storage

Transport	Observe the instructions as stated on the transport packaging, otherwise the products may get damaged. Transport temperature: -40 .. +80°C (-40 .. +176°F) Transport humidity: 20 .. 85% Transport incoming inspections must be carried out to check for possible transport damage.
Storage	Products must be stored at a dry and clean place. They must be protected from influence of corrosive environment, vibration and exposure to direct sunlight. Storage temperature: -40 .. +80°C (-40 .. +176°F) Storage humidity: 20 .. 85%

Approvals

Non-hazardous Locations	CE TR-CU	EN 61010-1 (IEC/CB)	
Hazardous Locations *	ATEX IEC-Ex TR-CU INMETRO	Dust explosion Dust explosion Dust explosion Dust explosion	ATEX II 1/2 D Ex t IIIC T! Da/Db IP6X IEC-Ex t IIIC T! Da/Db IP6X DIP A20/A21 Ex t IIIC T! Da/Db IP6X
EMC	EN 61326 - A1		
RoHS conform	According to directive 2011/65/EU		
Pressure Equipment Directive (2014/68/EU)	<p>The units are not subject to this directive, because they are classified as „pressure-keeping equipment“ and do not have a pressurized housing (see Art.1, clause 2.1.4). The units are designed and manufactured in accordance to the Pressure Equipment Directive.</p> <p>The unit is NOT intended for use as a "equipment part with safety function" (Art.1, clause 2.1.3). If the units should be used as "equipment part with safety function", please contact the manufacturer.</p>		



* Depending on selected version

Options

Weather protection cover

If the measuring device is used outdoors, the use of the weather-protection-cover is recommended. It protects the device from all atmospheric influences such as:

- rain water
- condensation water
- excessively high temperatures due to insolation
- excessively low temperatures in winter

Material: PE, weather and temperature stable



For use in Hazardous Locations:
 only permitted for zone 22

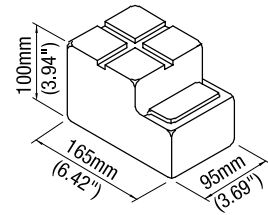

Flat gasket

On the face sealing of the process connection thread.
 Incl. sealing face for version with process connection G 1½" thread aluminium.

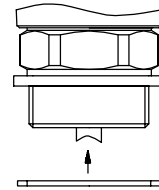

Extensions

(Kits, application only as full detector)

Rope extension

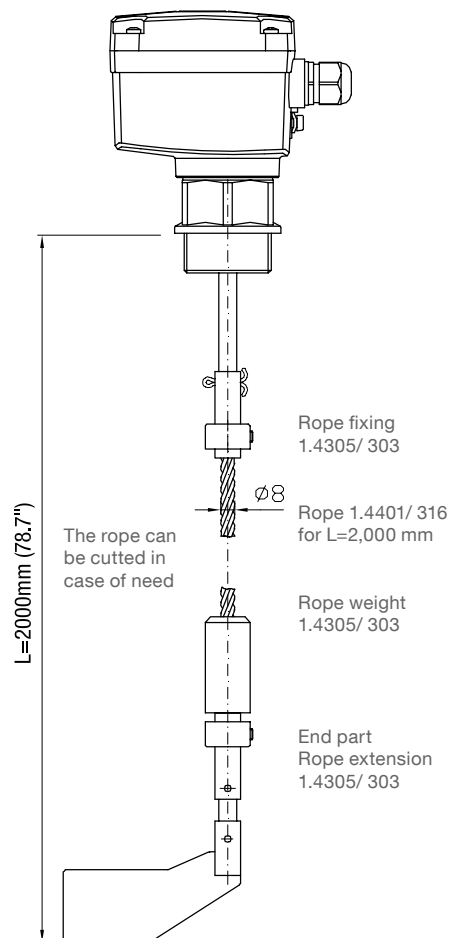

Pendulum shaft

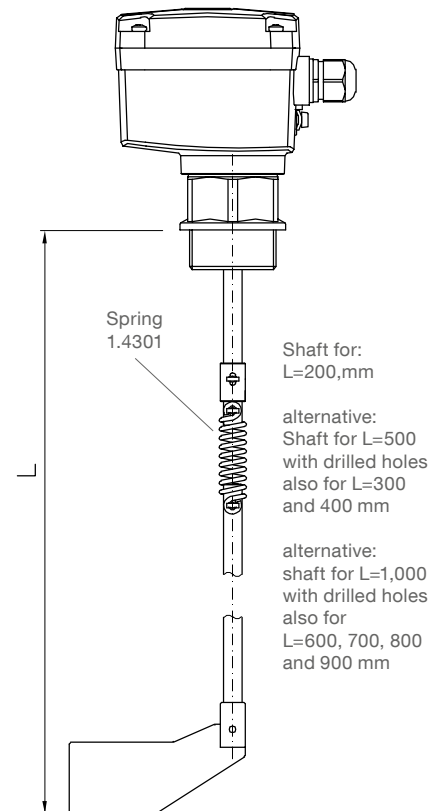

If necessary the shaft can be cutted approx. 10 to 15 mm below the required hole.

Mounting

! General Safety Instructions

Process pressure	Improper installation may result in loss of process pressure.
Chemical resistance against the medium	Materials of construction are chosen based on their chemical compatibility (or inertness) for general purposes. For exposure to specific environments, check with chemical compatibility charts before installing.
Mechanical load	The torque at the fastening spot must not exceed the specified ratings. See page 7 for details.
Mounting location	Keep away from incoming material and from silo walls. The installation has to be carried out, that the sensor elements cannot hit the wall of the silo. The flow of the medium and fixtures in the container must be considered.

! Additional Safety Instructions for Hazardous Locations

Installation regulations	For devices to be used in Hazardous Locations the respective valid installation regulations must be observed.
---------------------------------	---

Mounting instructions

Rotatable housing	The housing can be rotated against the threaded connection after mounting.
Direction of the cable glands	When the unit is mounted from the side, ensure, that the cable glands face downwards and are closed to avoid water penetration into the housing.
Sealing	Seal the process connection thread with Teflon tape or a flat gasket against process pressure.
Precaution for later dismantling	Use teflon tape to avoid seizing of aluminium process connection thread with the socket

Mounting/Electrical Installation

Mounting

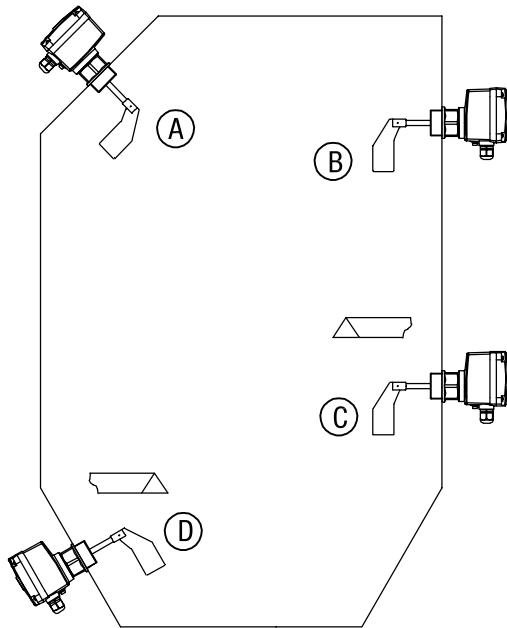

- A Full detector vertical and oblique from the top
- B Full detector horizontal
- C Demand or empty detector horizontal
Protective angle recommended, depending on load
- D Empty detector oblique from the bottom
Protective angle recommended, depending on load

Horizontal mounting (except full detector) : Boot shaped vane recommended (min. mech. load, because the vane aligns to the movement of the material).

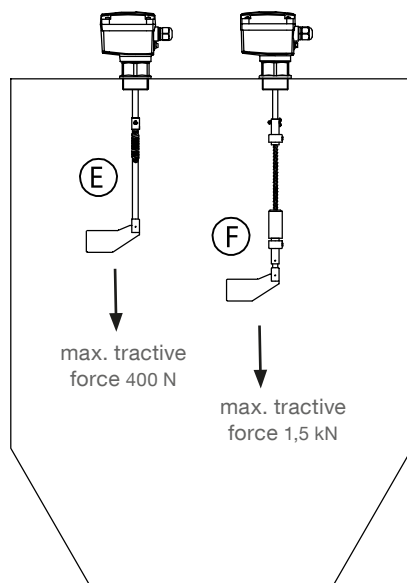

- E With pendulum shaft: Full detector vertical from the top
Observe max. tractive force.
- F With rope extension: Full detector vertical from the top
Observe max. tractive force.

Electrical Installation

! General Safety Instructions

Handling	In the case of improper handling or handling malpractice, the electric safety of the device cannot be guaranteed.
Installation regulations	The local regulations or VDE 0100 (Regulations of German Electrotechnical Engineers) must be observed. With use of 24 V supply voltage, an approved power supply with reinforced isolation to mains is required
Fuse	Use a fuse as stated in the connection diagrams (see pages 14).
RCCB protection	In the case of a fault, the supply voltage must be automatically switched off by a RCCB protection switch to protect against indirect contact with dangerous voltages.
Power supply switch	A voltage disconnection switch must be provided near the device.
Wiring diagram	The electrical connections are made in accordance with the wiring diagram.
Supply voltage	Compare the supply voltage applied with the specifications given on the electronic module and name plate before switching the device on.
Cable gland	The screwed cable gland and closing element must have following specifications: Ingress protection IP66, temperature range from -40°C to +70°C, UL or VDE or INMETRO certified (depending on the country where the unit is installed), pull relief. Make sure that the screwed cable gland safely seals the cable and that it is tight (danger of water intrusion). Cable glands that are not used have to be sealed with a blanking element.
Field wiring cables	<ul style="list-style-type: none"> • The diameter has to match to the clamping range of the used cable gland. • The cross section has to match with the clamping range of the connection terminals and consider the max. current. • All field wirings must have insulation suitable for at least 250 V AC. • The temperature rating must be at least 90°C (194°F). • If higher immunity interferences as specified in the stated EMC standards are present (see chapter approval), a shielded cable is required, otherwise an unshielded instrumentation cable is satisfactory.
Guiding the cables in the terminal box	Cut the field wiring cables to appropriate length to fit properly into the terminal box.
Microswitch protection	Provide protection for microswitch contacts to protect the device against inductive load surges.
Protection against static charging	The housing of the unit must be grounded to avoid static charging of the unit. This is particularly important for applications with pneumatic conveying and non-metallic containers.

Electrical installation

! Additional Safety Instructions for Hazardous Locations

Extenal equipotential bonding terminal

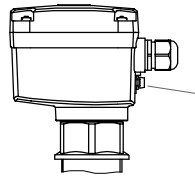

Connect to equipotential bonding of the plant

Field wiring

A strain relief must be provided for the field wiring cables, when the device is installed with the factory provided cable glands.

Cable glands for ATEX/ IEC-Ex/ INMETRO/ TR-CU

Installation according to the regulations of the country, where the product is installed.

Not used entries have to be closed with blanking elements certified for this purpose.

Where applicable the factory provided parts must be used.

A strain relief must be provided for the field wiring cables, when the device is installed with the factory provided cable glands.

The diameter of the field wiring cable must match to the clamping range of the cable clamp.

If other than the factory provided parts are used, following must be ensured:
 The parts must have an approval adequate to the approval of the level sensor (certificate and type of protection).

The approved temperature range must be from the min. ambient temperature of the level sensor to the max. ambient temperature of the level sensor increased by 10 K.
 The parts must be mounted according to the instructions of the supplier.

Commissioning

Commissioning only with closed lid.

Opening the lid

Before opening the lid take care, that no dust deposits or whirlings are present.
 Do not remove the lid (cover) while circuits are alive.

Connection

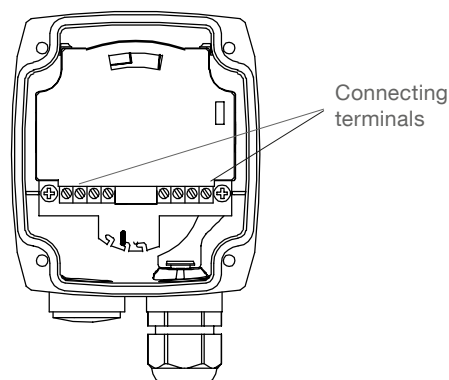

Connecting terminals

Electrical installation

Version:

- AC
- DC
- Universal voltage

Power supply:

- **AC version:**
 24 V or 48 V or 115 V or 230 V 50/ 60 Hz max. 4 VA
 All voltages $\pm 10\%$ ⁽¹⁾
 Supply voltage as selected.
 External fuse: max. 10 A, fast or slow, HBC, 250 V
- **DC version:**
 24 V DC $\pm 15\%$ ⁽¹⁾ max. 2.5 W
 External fuse: not required
- **Universal voltage:**
 24 V DC $\pm 15\%$ ⁽¹⁾ max. 4 W
 22 .. 230 V 50/ 60 Hz $\pm 10\%$ ⁽¹⁾ max. 10 VA
 External fuse: not required

⁽¹⁾ including $\pm 10\%$ of EN 61010

Signal and alarm output:

Micro switch or relay, SPDT contact
 max. 250 V AC, 2 A, 500 VA ($\cos\phi = 1$)
 max. 300 V DC, 2 A, 60 W
 External fuse: max. 10 A, fast or slow, HBC, 250 V

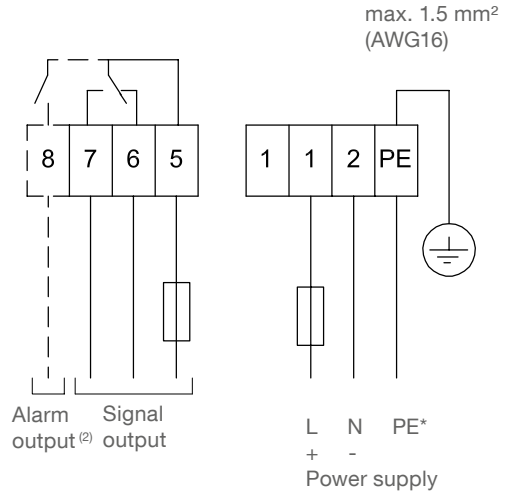

⁽²⁾ With option Fail safe alarm (rotation control)
 Contact open when de-energised

Version:

- PNP

Power supply:

24 V DC $\pm 15\%$ ⁽¹⁾
⁽¹⁾ including $\pm 10\%$ of EN 61010
 Input current: max. 0.6 A

Signal output:

Load max. 0.4 A
 Output voltage equal to input voltage, drop < 2.5 V
 Open collector
 Protected against short circuit and overload

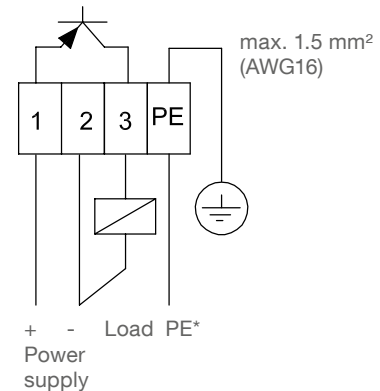

* Protection against static charge:

The PE terminal of the unit must be grounded to avoid static charging of the unit.
 This is particularly important for applications with pneumatic conveying.

Signal and alarm output

Overview

Overview of signal and alarm output for the different electronics versions: see page 4

Signal output: Switching logic

Versions

- AC
- DC

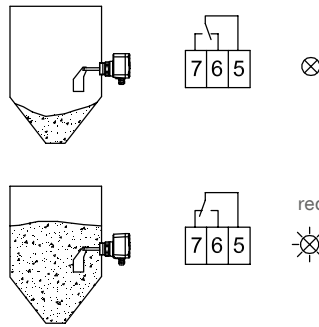

Versions

- PNP
- Universal voltage

FSH: Set in case of using the sensor as a full detector.

Power failure or line break is regarded as „full“ signal (protection against overflowing).

FSL: Set in case of using the sensor as an empty detector.

Power failure or line break is regarded as „empty“ signal (protection against running dry).

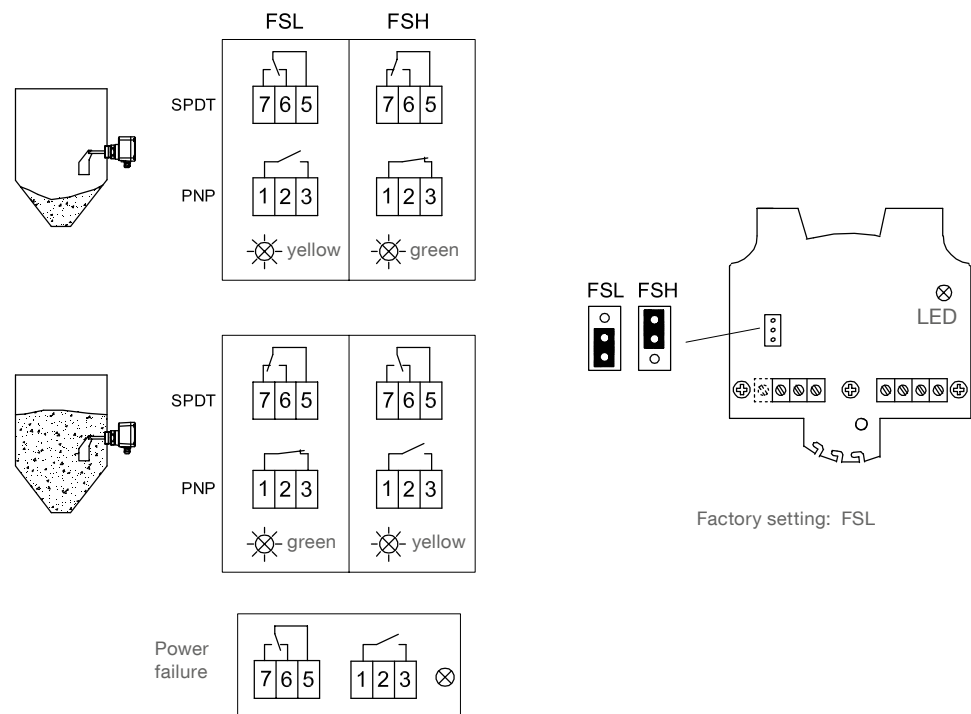

Signal and alarm output

Signal output: Delay

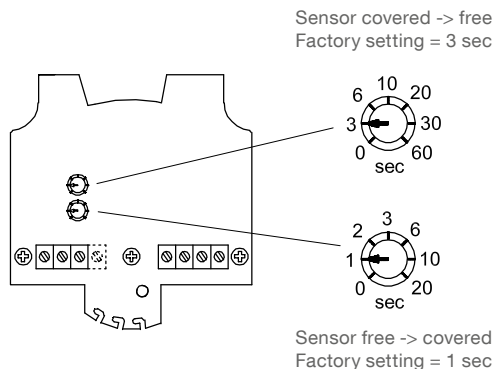

Alarm output (Fail safe alarm)

Switching and timing behaviour:

If the sensor is not covered, the rotating paddle shaft will send pulses at 20 sec intervals. In case of fault, the pulses are missed. After 30 sec the alarm relay will open.

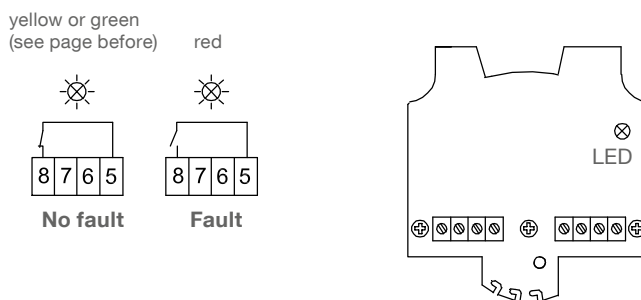

Connection example:

Full detector with maximum safety:
 The output signal opens in case of:

- full signal or
- failure of supply voltage or
- defect of the connection wires or
- defective unit

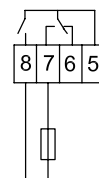

Signal output

Settings: Sensitivity

Adjustment of the spring

The spring is adjustable in 3 positions. It should be changed only if necessary.

- „Fine“: for light material
- „Medium“: suitable for nearly every material (factory setting)
- „Coarse“: for very sticky material

The spring can be changed via a small plier.

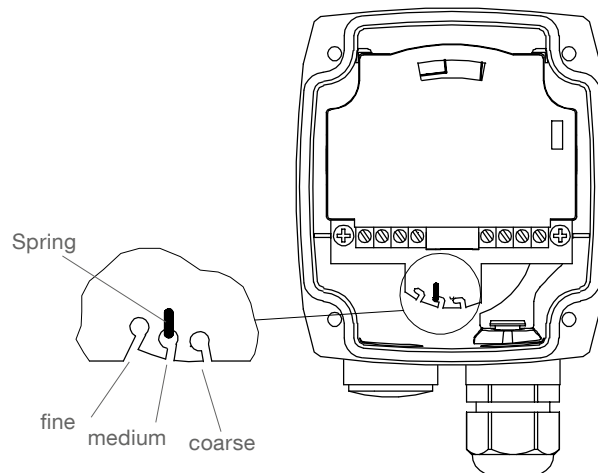

Sensitivity

The table shows approximate values for the minimum densities, at which a normal function should be possible.

Vane	*Minimum density in g/l = kg/m ³ (lb/ft ³) (without guarantee)			
	Vane completely covered with bulk material		Bulk material covers vane up to 100 mm (3.93")	
	Spring adjustment		Spring adjustment	
	fine	medium (Factory setting)	fine	medium (Factory setting)
Boot shaped vane 40 x 98	200 (12)	300 (18)	100 (60)	150 (9)
Boot shaped vane 35 x 106	200 (12)	300 (18)	100 (60)	150 (9)
Boot shaped vane 28 x 98	300 (18)	500 (30)	150 (9)	200 (12)
Boot shaped vane 26 x 77	350 (21)	560 (33)	200 (12)	250 (15)
Hinged vane 98 x 200 b=37 double sided	70 (4.2)	100 (60)	35 (2.16)	50 (3)
Hinged vane 98 x 200 b=28 double sided	100 (60)	150 (9)	50 (3)	75 (4.5)
Hinged vane 98 x 100 b=37 single sided	200 (12)	300 (18)	100 (60)	150 (9)
Hinged vane 98 x 100 b=28 single sided	300 (18)	500 (30)	150 (9)	250 (15)

The above mentioned data is a guideline and is for loose, non compacted material. During the filling the bulk density can change (e. g. for fluidised material).

*For versions with option 26 (heating of housing) the above mentioned data must be multiplied by 1.5.

Maintenance

Opening the lid (cover)  Before opening the lid for maintenance reasons observe following items:

- Do not remove the lid while circuits are alive.
- No dust deposits or whirlings are present.
- No rain can enter into the housing.

Frequent check of the unit  To ensure durable safety in hazardous locations and with electrical safety, following items must be checked frequently depending on the application:

- Mechanical damage or corrosion of any components (housing side and sensor side) and of the field wiring cables.
- Tight sealing of the process connection, cable glands and enclosure lid.
- Properly connected external PE cable (if present).

Cleaning  If cleaning is required by the application, following must be observed:

- Cleaning agent must comply with the materials of the unit (chemical resistance). Mainly the shaft sealing, lid sealing, cable gland and the surface of the unit must be considered.

 The cleaning process must be done in a way, that:

- The cleaning agent cannot enter into the unit through the shaft sealing, lid sealing or cable gland.
- No mechanical damage of the shaft sealing, lid sealing, cable gland or other parts can happen.

A possible accumulation of dust on the unit does not increase the maximum surface temperature and must therefore not be removed for purposes of maintaining the surface temperature in hazardous locations.

Function test A frequent function test may be required depending on the application.

 Observe all relevant safety precautions related with a safe work depending on the application (e.g. hazardous locations, hazardous bulk material, electric safety, process pressure).

 This test does not proof if the sensor is sensitive enough to measure the material of the application.

- Function test is done by stopping the rotating paddle with appropriate means and monitor if a correct change of the signal output from uncovered to covered happens.

Production date The production date can be traced by the serial number on the typeplate. Please contact the manufacturer or your local distributor.

Spare parts All available spare parts are stated in the selection list

Notes for use in Hazardous Locations

Zone classification

	Useable in zone	ATEX Category	IEC-Ex/ INMETRO Equipment Protection Level (EPL)
Dust applications	20, 21, 22	1 D	Da
	21, 22	2 D	Db
	22	3 D*	Dc

* in case of conductive dust additional requirements for the installation are necessary.

General Notes

Marking

Devices with Ex approval are marked on name plate.

Process pressure for ATEX/ IEC-Ex



The device construction allows process over-pressure upto 0.8 bar (11.6 psi). These pressures are allowed for test purposes. The definition of the ATEX and IEC-Ex is only valid for a container-over-pressure between -0.2 .. +0.1 bar (-2.9 .. +1.45 psi). For higher or lower pressures the approval is not valid.

Process and ambient temperature

The permitted temperature ranges are marked on the name plate.

Permitted zones for mounting in partition wall

EPL*	Db
Category**	2D
Zone	21

EPL*	Da
Category**	1D
Zone	20

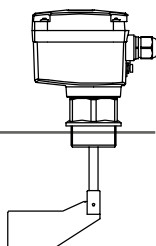

* For IEC-Ex/ INMETRO

** For ATEX

Max. Surface Temperature and Temperature Code

The temperature marking on the name plate  refers to the instruction manual. In the following tables the relevant temperature ratings are shown.

The maximum surface temperature (resp. temperature class) is the warmest temperature of the unit which could occur during malfunction (according to Ex-definition).

Max. ambient temperature	Max. process temperature	Max. surface temperature	Temperature class
40°C (104°F)	60°C (140°F)	100°C (212°F) 120°C (248°F) ⁽¹⁾	T5 T4 ⁽¹⁾
50°C (122°F)	70°C (158°F)	110°C (230°F) 120°C (248°F) ⁽¹⁾	T4
60°C (140°F)	80°C (176°F)	120°C (248°F)	T4

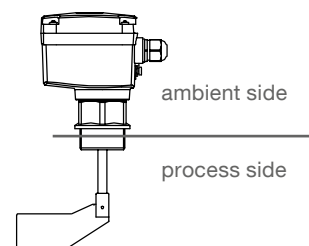

⁽¹⁾ With use of electronic "Universal voltage"

Disposal

The product consists of materials which can be recycled, details of the used materials see chapter "Technical data - mechanical data".

Recycling must be done by a specialised recycling company.

Since the product is not subject to the WEEE directive 2002/96/EG, it is not permitted to bring it to a public recycling station.